

Dalang

AK988D





Dalang Communication Technology Co., Ltd Product Specification

Product Name:	<u>GNSS Receiver</u>
Product Model:	<u>AK988D</u>
Version Number:	<u>V 1.0</u>
Revision Date:	<u>2026.02.03</u>

Confidentiality Statement

This document and the information contained within are the property of **"Dalang Communication Technology Co., Ltd"**, and are for use only by authorized individuals for specific purposes. This document contains confidential information. Without explicit written permission from **"Dalang Communication Technology Co., Ltd"**, no person or group may copy, distribute, disseminate, display, or disclose this document or any part of it to a third party in any form. Recipients must strictly adhere to confidentiality obligations, protect the information in the document from being disclosed or misused, and ensure that all relevant personnel follow the same confidentiality rules. Individuals or organizations violating this statement will face legal prosecution and/or contractual penalties.

Thank you for your support and cooperation in protecting the confidential information of **"Dalang Communication Technology Co., Ltd"**.

Contents

1 Product Application Scenarios	1
Figure 1 Product Application Scenarios	1
2 Features	2
3 Structural Characteristic	3
Figure 2 Interface Definition Diagram	3
Table 1 M8 Interface Definition	3
Figure 3 Schematic diagram of connecting wires	4
Figure 4 Complete K987 Connection Scheme	4
Table 2 Complete Component Description	4
4 Specifications	5
Table 3 Product Specifications	5
5 Product Photos	7
Figure 6 Product Images	7
6 status indicator	8
7 Common configuration instructions	9
8 4G RTK ROVER instructions	10
8.1 Preparation work	10
8.2 Parameter configuration	10
8.3 Change bluetooth name	11
8.4 Firmware upgrade	12
9 Typical applications	13

1 Product Application Scenarios

AK988D is a terminal device that integrates 4G network transmission and high-precision combined navigation positioning and orientation. It transmits RTK differential base station data to the GNSS dual antenna orientation module through the 4G network, and combines the module's built-in MEMS IMU and deep coupling algorithm to achieve continuous accurate positioning and attitude output in complex environments. The terminal supports Ntrip communication protocol and is compatible with network base station services such as Chihiro location, CORS stations, and self built stations. At the same time, it has added Beidou-3 B2b (PPP) satellite based enhancement function, covering remote vehicle scenarios without 4G network.

The equipment adopts industry-leading 4G hardware solutions and supports most domestic and European operator network standards. The 9-36V wide power input design is suitable for multiple scenarios such as vehicle and outdoor operations. RTK positioning and directional data support RS232 and BT output, which can be widely used in intelligent driving, unmanned small car navigation, intelligent robot obstacle avoidance, precise operation equipment attitude control and other fields. Refer to Figure 1 for details.



Figure 1 Product Application Scenarios

2 Features

In this chapter, we will delve into and comprehensively elaborate on the functionalities and operating principles of the K988D, detailing how it plays a pivotal role in various applications as follows:

- 1. Dual antenna high-precision directional and RTK positioning:** Supports BDS, GPS, GLONASS, Galileo, QZSS signals, providing high-precision heading angle output (with an accuracy of better than 0.2° at a baseline of 1m) while achieving centimeter level positioning.
- 2. Deep coupling integrated navigation:** Built in high-performance MEMS IMU, using deep coupling algorithm to ensure the continuity and reliability of navigation information in case of poor signal.
- 3. High performance anti-interference:** Provides 65dBc narrowband anti-interference capability, especially suitable for environments with complex electromagnetic interference such as vehicle mounted radar and communication equipment.
- 4. 4G network differential service:** supports accessing various Ntrip differential sources through 4G network.
- 5. Multi source data output:** Positioning, orientation, and raw data can be output through RS232 serial port or Bluetooth.
- 6. Wide voltage industrial design:** adopting 9-36V wide voltage input, suitable for harsh industrial and vehicle environments.

3 Structural Characteristic

In this section, we will conduct an in-depth analysis of the product's design details, presenting its aesthetic features and precise interface specifications through detailed structural diagrams. This perspective aims to provide a comprehensive framework, thereby enhancing the understanding and perception of the product's architecture. Refer to Figure 2, Table 1, Figure 3, Table 2, Figure 4.

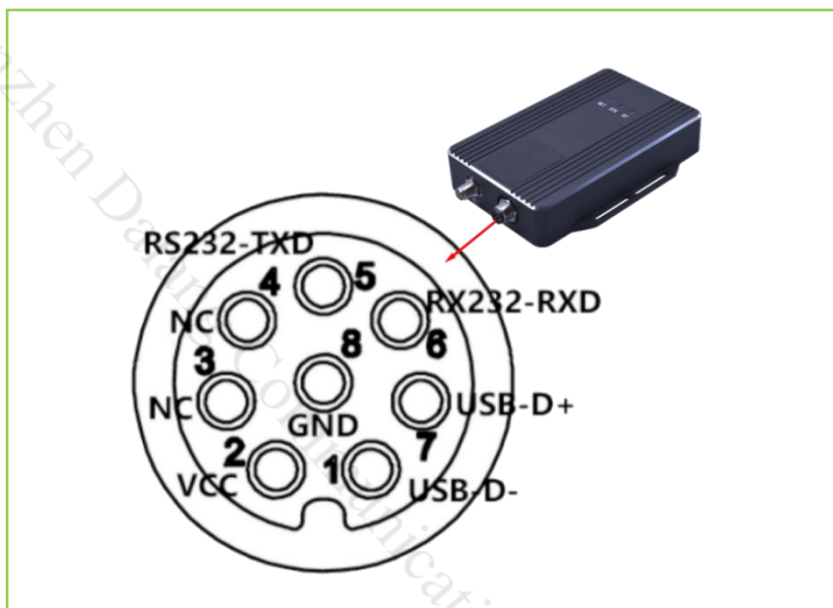

Figure 2 Interface Definition Diagram

Table 1 M8 Interface Definition

Serial Number	Interface Name	Function Introduction
1	USB-D-	Parameter configuration USB interface D-
2	VCC	power input DC9-36V
3	NC	empty
4	NC	empty
5	RS232-TXD	RTK positioning output RS232-TXD
6	RS232-RXD	RTK positioning output RS232-RXD
7	USB-D+	Parameter configuration USB interface D+
8	GND	Grounding
Antenna interface		
1	GNSS	Active positioning antenna, 3.3V, SMA interface*2
2	NET	4G antenna interface, SMA

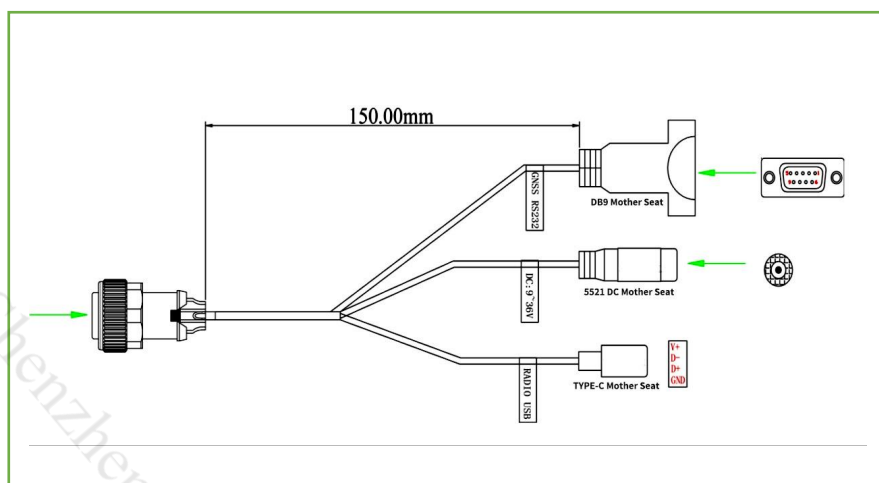

Figure 3 Schematic diagram of connecting wires



Figure 4 Complete K987 Connection Scheme

Table 2 Complete Component Description

Number	Name	Quantity	Remarks
1	AK988EU terminal	1	
2	Connecting line	1	M8 aviation head to type C; DC-DC power supply; DB9 female head
3	GNSS antenna	2	Full system full frequency antenna
4	Coaxial line	2	5mTNC to SMA, 50-3 wires
5	4G antenna	1	SMA connector

4 Specifications

In this section, we will provide a detailed list and explanation of the product's chip features, sensitivity, accuracy, operating principles, and other technical details, as detailed in Table 3.

Table 3 Product Specifications

Specifications			
GNSS module	1	operating frequency	BDS-3: B1I, B1C, B2b (PPP) GPS: L1 C/A, L1C, L2 GLONASS: G1, G2 Galileo: E1, E5b QZSS: L1C/A, L1C, L2
	2	reception channel	1500 channels
	3	Single point positioning (RMS)	Plane: 1.5m
			Elevation: 2.5m
	4	RTK(RMS)	Flat: 0.01m+1ppm
			Elevation: 0.015m+1ppm
		Directional accuracy (RMS)	0.2 ° /1 meter baseline (static, open sky)
	5	startup performance	Cold start:<30s
			Hot start:<5s
			RTK initialization:<5s (typical value)
			Lost lock recapture: $\leq 1s$
	6	anti-interference capability	Dry to solid ratio (J/S): $\geq 65dBc$ Supporting interference types: sweep frequency, single frequency, multi tone, narrowband, pulse
	7	Gyroscope performance	Range: $\pm 300^\circ/s$
Zero bias instability (Allan variance): $5^\circ/h$			
8	Performance of accelerometer	Range: $\pm 16g$	
		Zero bias instability (Allan variance): $50\mu g$	
9	Dead reckoning (DR) accuracy	Distance error: 0.8% (2 σ , connected to odometer)	

	10	Speed accuracy (RMS)	0.03 m/s
	11	Timing accuracy (RMS)	20ns
4G module (Network frequency band)	1	LTE FDD	B1/3/5/8
	2	LTE TDD	B34/38/39/40/41(Full frequency band)
	3	GSM/GPRS/EDGE	NA
4G module (Spread speed)	1	LTE FDD (Mbps)	10.3(DL)/5.1(UL)
	2	LTE TDD (Mbps)	9.1(DL)/3.1(UL)
Bluetooth module	1	Bluetooth version	2.0
	2	operating frequency band	2.4G
	3	Air speed	2Mbps
	4	reference distance	10m
Data format	1	differential data	RTCM3.X
	2	output format	NMEA-0183, RTCM3.X
	3	Data update rate	1Hz-20Hz (Default 1Hz)
	4	INS/IMU raw data update rate	100Hz
Power supply	1	voltage	DC +9V~36V
	2	power consumption	<3W
	3	operating current	≤145mA/12V
	4	indicator light	1NET, 1RTK, 1BT
Physical parameters	1	size	100mm*61.8mm*18.75mm
	2	weight	180g
	3	housing material	aluminium
	4	interface	SMA*3/M8-8Paviation connector
Environment	1	Operating Temperature	-30°C~ +70°C
	2	Storage temperature	-40°C~ +85°C
	3	humidity	95% condensation
	4	Protection grade	IP65
	5	seismic resistance	Resist the impact of a 1-meter free fall

5 Product Photos

In this chapter, we will showcase real-life images of the product, as shown in Figure 6. These images provide a detailed view of our product from various angles and perspectives. We believe that through authentic representation, we can better convey the value and concept of the product, thereby enhancing your trust and satisfaction.



Figure 6 Product Images

6 status indicator

NET (green) light	Chang Liang	The 4G module is powered on, but PPP dialing is not completed
	flash	PPP dial-up completed
	Slow Flash	Registered RTK NTRIP base station
RTK (blue) light	Chang Liang	Not located
	flash	Positioned but not entered RTK fixed solution
	Slow Flash	RTK fixed solution
BT (blue) light	Chang Liang	Bluetooth connected
	flash	Bluetooth not connected

Note: Slow flashing: on for 400ms, off for 800ms

Flash: on 200ms, off 200ms

7 Common configuration instructions

NO.	Instruction	Describe	Notes
1	AT+set_ntrip_param,140.207.166.210,25001,,SZ-DL-8KM-RTCM32#	Set ntrip IP, port, username, password, and loading point	Please separate each item with a comma. If there is no username or password, do not write it, but also separate it with a comma
2	AT+get_ntrip_param#	Query ntrip parameters	
3	AT+get_verno#	Versions Query	
4	AT+set_to_bt,NAMEAK987#	Set Bluetooth name	Note that setting the Bluetooth name must be done when the Bluetooth is not connected. When changing it, disconnect the Bluetooth connection first. The AK987 command shows the Bluetooth name displayed after the change, which can be changed according to your own needs
5	AT+set_uart_gps,1#	Enable MCU serial port forwarding of GPS information	This command will be saved in case of power failure, but if the factory reset command is sent, it will default to no output
6	AT+set_uart_gps,0#	Turn off MCU serial port forwarding GPS information	
7	AT+set_gps_rtk_timer,10#	Set 10 seconds to send GGA information to the ntrip server	10 "is 10 seconds, can be changed to 5 seconds or other, default is 10 seconds
8	AT+set_to_gps,log gpgsv ontime 1#	Positioning module outputs gpgsv data	The instructions starting with "AT+set_to-ugps" are forwarded to the positioning module, and the subsequent instructions are the positioning module instructions, which can be modified according to the GPS module instructions

Note: AT commands can be sent from MCU serial port or Bluetooth. When sending commands via Bluetooth on a mobile app, try to edit the text in English as much as possible to avoid text errors

8 4G RTK ROVER instructions

8.1 Preparation work

8.1.1 Connect the AK987 configuration USB cable to the computer USB (Windows 10 and above computer systems will automatically generate serial port numbers, Windows 7 and above computer systems need to install the CH340 serial port driver first). Open the RTKUpdateTool_1.1CH.exe configuration tool software on the computer

8.2 Parameter configuration

Open the RTKUpdateTool_1.1CH.exe software and select a good string of slogans, baud rate 115200, click to open the serial port, fill in the IP (or domain name), port, username, password, access point in the corresponding window of the software interface (the IP bar supports entering the domain name, username and password If not, do not fill in), click Settings after all input is completed, and the bottom of the software returns "wait 10s system reset! set_ntrip_param", 000.000.000.000, 25001, SZ-DL-8KM-RTCM32 ok #indicates that the setting is successful (the content of the underlined part is the IP port and other parameters actually set in, and the actual content is consistent with the setting content).

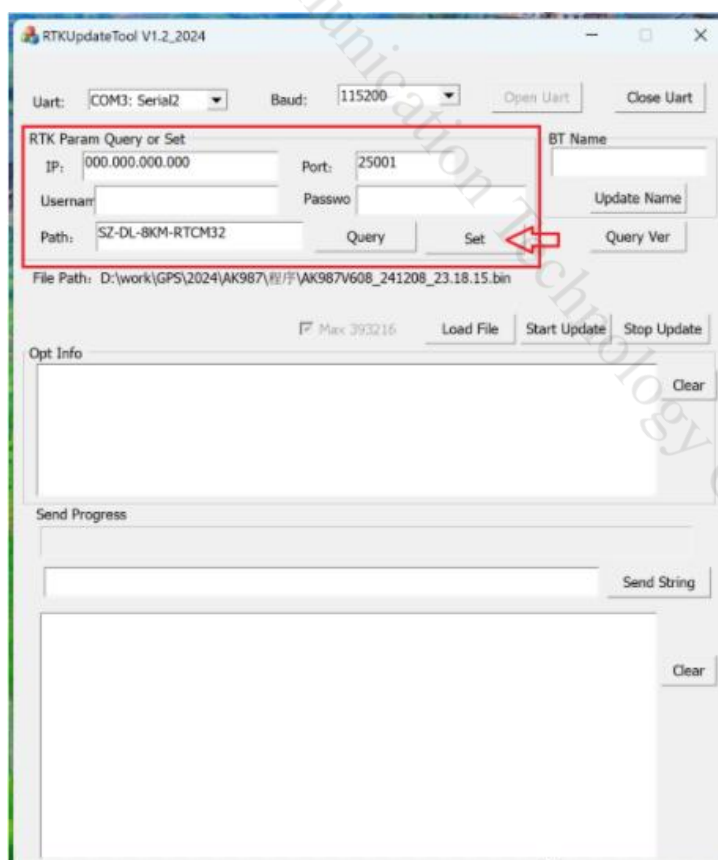

8.3 Change bluetooth name.

AK987 supports customers to modify the Bluetooth name by themselves. Just fill in the Bluetooth name you want to modify in the Bluetooth name window of the RTKUpdateTool_1.1CH.exe tool, and click Modify Name to complete the change. The bottom interface of the software returns set_to_bt, NAMEAK987, ok # (the underlined content is the changed Bluetooth name). It should be noted that the modification of the Bluetooth name must be carried out without a Bluetooth connection, that is, when you see the end point BT indicator flashing, the Bluetooth name must not exceed 16 characters.

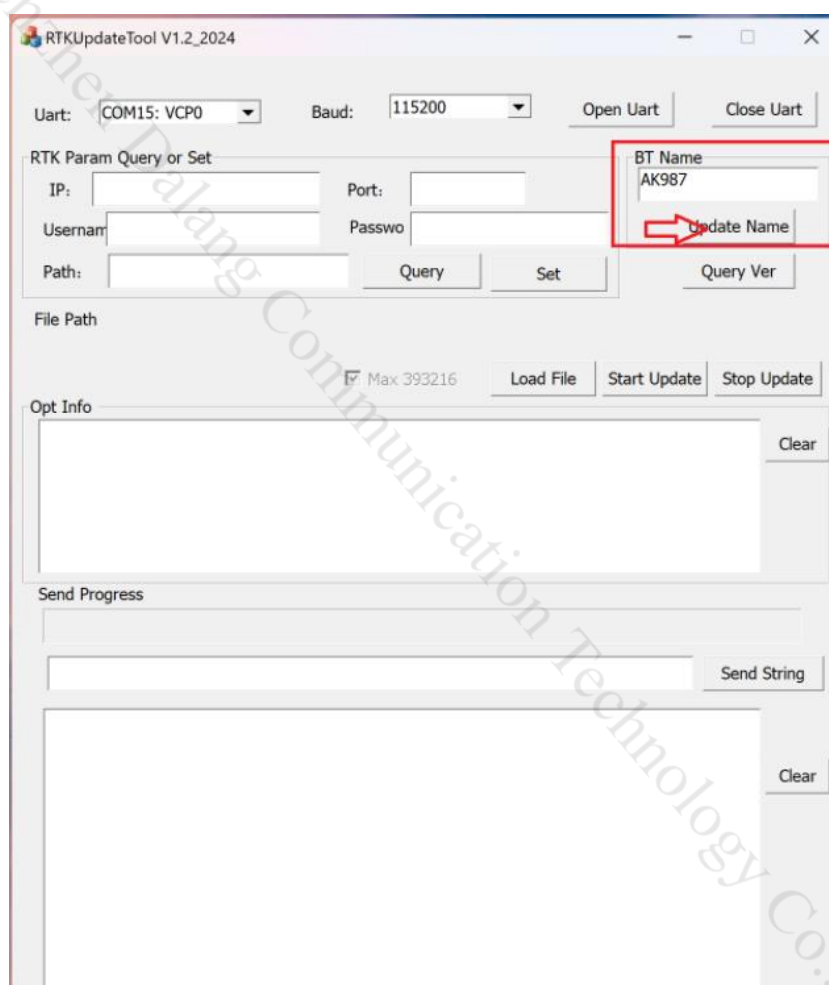

8.4 Firmware upgrade

RTKUpdateTool_1 tool software can be AK987 product firmware upgrade, open the software to select a good serial port, baud rate 115200, click to open the serial port, click to load the file to select the firmware, and then click to start the upgrade, waiting for the progress bar to complete, and the sending window shows the upgrade is complete, the current version of the sending window is the version before the upgrade, see the receiving window shows system start that has been upgraded and end point restart, then click the query version button, the receiving window returns to the upgraded version.

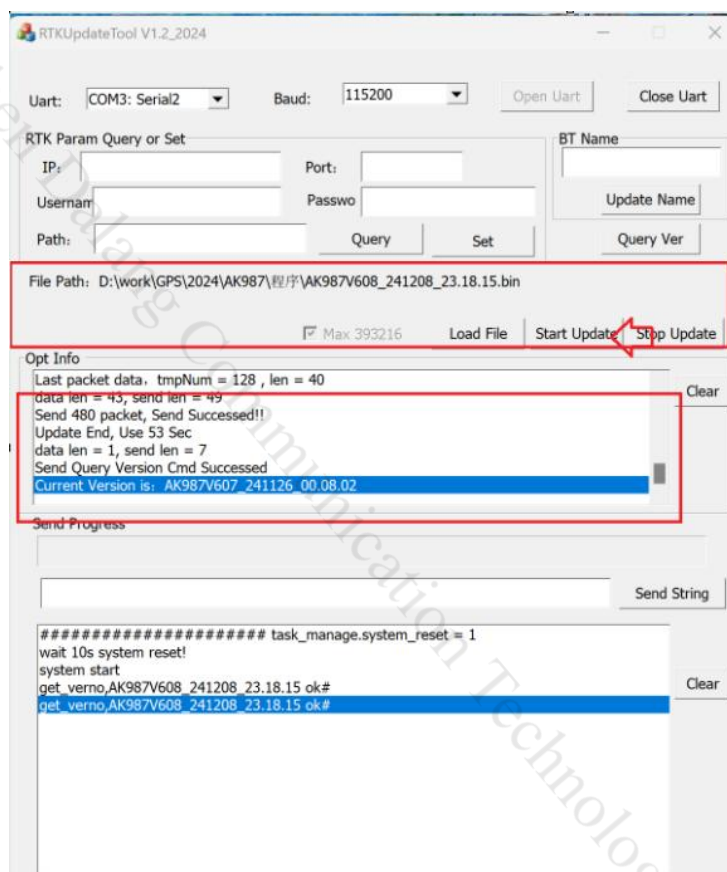

9 Typical applications

9.1 Common data transmission modules are difficult to provide reliable differential data connections, resulting in serious packet loss issues. For this purpose, the company provides a solution based on 4G network (as shown in the figure below). The benchmark station sends differential data to the server through a wired network and is cached by the server. Mobile stations access servers through 4G networks to obtain differential data. This solution can greatly expand the coverage area of base stations, and mobile stations equipped with 4G network cards can simultaneously transmit positioning results back to designated servers.

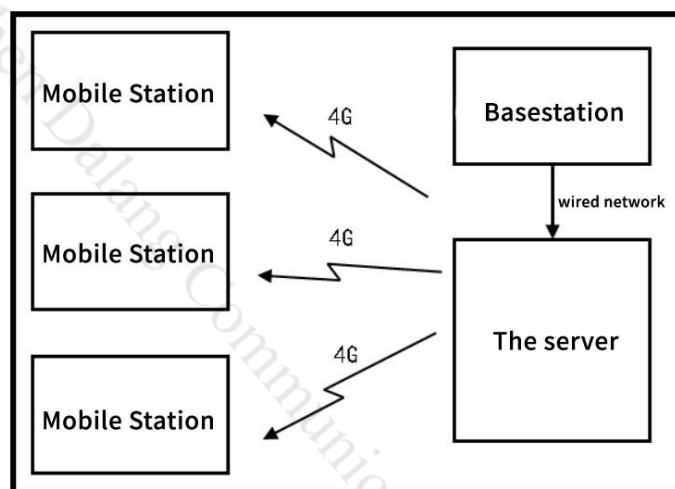

The circuit diagram of the mobile station is as follows:

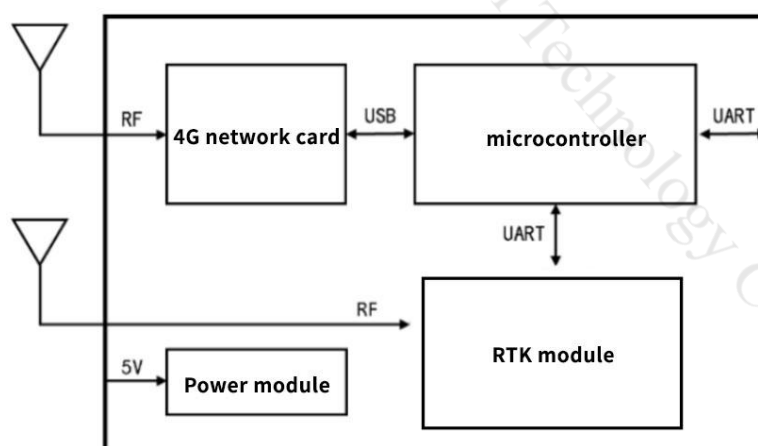

In practical applications, the number of mobile stations that a server can access simultaneously is limited only by server performance and is more suitable for a large number of users. Requirements between the server and the base station: the server can be directly accessed from the public network (with a public IP address), and a network connection can be established between the base station and the server (either through the public network or local area network).

9.2 In high-precision positioning applications without reference stations, the module needs to cooperate with the 4G communication module to obtain differential data. We provide Qianxun with differential data sources nationwide, and users can obtain high-precision positioning results without deploying base stations. The circuit diagram is as follows:

