

Dalang

AK701





Dalang Communication Technology Co., Ltd Product Specification

Product Name: GNSS ANTENNA

Product Model: AK701

Version Number: V 1.0

Revision Date: 2025.12.31

Confidentiality Statement

This document and the information contained within are the property of **"Dalang Communication Technology Co., Ltd"**, and are for use only by authorized individuals for specific purposes. This document contains confidential information. Without explicit written permission from **"Dalang Communication Technology Co., Ltd"**, no person or group may copy, distribute, disseminate, display, or disclose this document or any part of it to a third party in any form. Recipients must strictly adhere to confidentiality obligations, protect the information in the document from being disclosed or misused, and ensure that all relevant personnel follow the same confidentiality rules. Individuals or organizations violating this statement will face legal prosecution and/or contractual penalties.

Thank you for your support and cooperation in protecting the confidential information of **"Dalang Communication Technology Co., Ltd"**.

Contents

| | |
|---|---|
| 1 Product Application Scenarios | 1 |
| Figure 1 Product Application Scenarios | 1 |
| 2 Features | 2 |
| 3 Structural Characteristic | 3 |
| Figure 2 Product structure diagram (mm) | 3 |
| Figure 3 Product correlation chart | 3 |
| Figure 4 Process flow diagram | 3 |
| 4 Specifications | 4 |
| Table 1 Product Specifications | 4 |
| 5 Product Photos | 6 |
| Figure 5 Product Images | 6 |

1 Product Application Scenarios

The AK701-GNSS antenna is a high-performance device with advanced eight-arm coupling and four-feed point technology. It supports Beidou, GPS, GLONASS, and GALILEO systems, receiving L1, L2, and L5 signals. With a built-in low-noise amplifier (LNA) and dualstage filter system, it enhances signal quality and clarity, excelling in anti-interference. Ideal for high-precision and multi-system applications like geodetic surveying, precision agriculture, and vehicle navigation. See Figure 1 for details.



Figure 1 Product Application Scenarios

2 Features

In this chapter, we will delve into and comprehensively elaborate on the functionalities and operating principles of the AK701, detailing how it plays a pivotal role in various applications as follows:

1. **Multi-Arm Helix Technology:** The antenna features a multi-arm helix design, ensuring efficient right-hand circular polarization, optimizing signal reception, and maintaining phase center stability. This reduces measurement errors, enhancing positioning accuracy and reliability.
2. **High Gain and Gain Roll-Off Performance:** The antenna unit boasts high gain characteristics with minimal gain roll-off, meaning it can maintain good reception even for low-elevation satellite signals, improving overall signal stability and coverage.
3. **Low Noise and High Gain Amplifier:** The sophisticated amplifier design, combined with excellent out-of-band suppression, effectively reduces background noise while enhancing the desired signal strength, making the antenna more effective in receiving weak signals, especially in high-interference environments.
4. **Compact and Lightweight:** The antenna's small size and light weight make it easy to carry and install, ideal for applications requiring mobility or rapid deployment in multiple locations.

3 Structural Characteristic

In this section, we will conduct an in-depth analysis of the product's design details, presenting its aesthetic features and precise interface specifications through detailed structural diagrams. This perspective aims to provide a comprehensive framework, thereby enhancing the understanding and perception of the product's architecture. Refer to Figure 2, Figure 3, Figure 4.

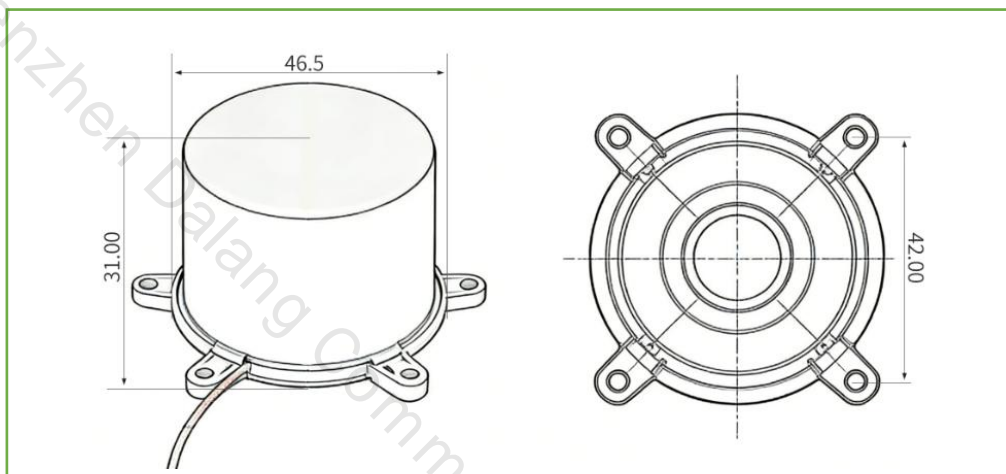

Figure 2 Product structure diagram (mm)



Figure 3 Product correlation chart

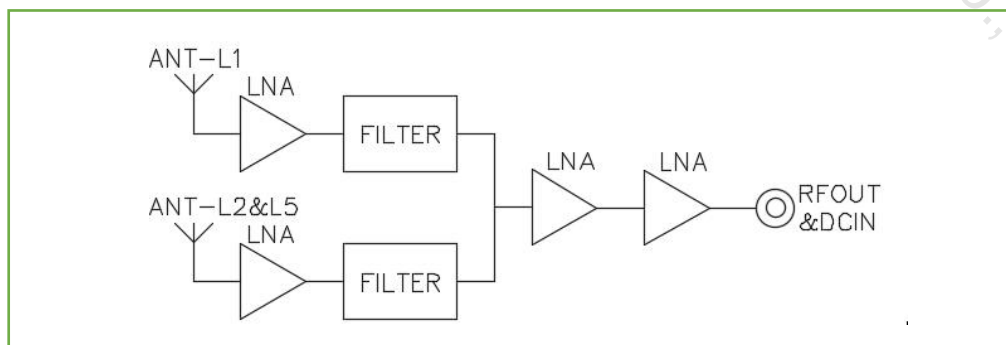

Figure 4 Process flow diagram

4 Specifications

In this section, we will provide a detailed list and explanation of the product's chip features, sensitivity, accuracy, operating principles, and other technical details, as detailed in Table 1.

Table 1 Product Specifications

| II. Specification | | | |
|----------------------------|----|-------------------------|--|
| Electrical Characteristics | 1 | Operating Frequency | GPS: L1:1575.42±1.023MHz, L2:1227±1.023MHz, L5:1176±1.023MHz; Bei Dou: B1: 1561±2.046MHz, B2: 1207 ±2.046MHz. GLONASS: L1=1602+0.5625*k(MHz), L2=1246+0.4375*k(MHz); GALILEO: E1: 1575 |
| | 2 | Antenna Specifications | GPS, Bei Dou, GLONASS,GALILEO |
| | 3 | Frequency Range | 1170-1278/1559-1612MHz |
| | 4 | V.S.W. R | ≤2.0 |
| | 5 | Axial Ratio | Elevation at 90 degrees: ≤ 3 dB, Elevation at 15 degrees: ≤ 5 dB |
| | 6 | Gain | Elevation at 90 degrees: ≥ 6 dB, Elevation at 20 degrees: ≥ 0 dB |
| | 7 | Front to back Power | ±60 degrees: ≥ 15 dB |
| | 8 | Phase Center (mm) | <2 |
| | 9 | Impedence | 50Ω |
| | 10 | Polarization | RHCP |
| | 11 | Out-of-Band Suppression | 1268+100MHZ≥50db, 1170-100MHZ≥50db, 1602+100MHZ≥50db, 1561-100MHZ ≥50db. |

| | | | |
|--------------------------------------|---|-----------------------|--|
| LNA | 1 | LNA GAIN | $38 \pm 2\text{dB}$ |
| | 2 | V.S.W. R | <2 |
| | 3 | Noise Figure | <2.0 |
| | 4 | DC Voltage | 3.3~12V |
| | 5 | Current | $<35\text{ mA}$ |
| Mechanical Structure | 1 | Antenna Dimensions | $\Phi 46.5 * 31\text{mm}$ |
| | 2 | Product Weight | 18g |
| | 3 | RF Output Interface | MCX(Customizable) |
| | 4 | wire rod | RG178(Customizable) |
| | 5 | Line length | 150mm(Customizable) |
| | 6 | Antenna Housing | ABS+PC |
| Environmental Characteristics | 1 | Operating Temperature | $-40^{\circ}\text{C} \sim +85^{\circ}\text{C}$, 10%~95% RH |
| | 2 | Storage Temperature | $-55^{\circ}\text{C} \sim +100^{\circ}\text{C}$, 10%~95% RH |
| | 3 | Humidity | Sine sweep @1.5mmAM 10~55Hz each Axis |
| | 4 | Vibration Resistance | 95% No-condensing |

5 Product Photos

In this chapter, we will showcase real-life images of the product, as shown in Figure 5. These images provide a detailed view of our product from various angles and perspectives. We believe that through authentic representation, we can better convey the value and concept of the product, thereby enhancing your trust and satisfaction.



Figure 5 Product Images