

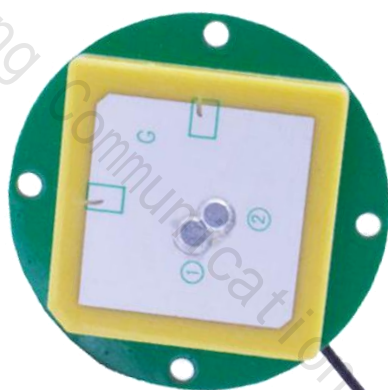

AK530-E





Dalang Communication Technology Co., Ltd Product Specification

Product Name:	GPS ANTENNA
Product Model:	AK530-E
Version Number:	V 1.0
Revision Date:	2024.07.04

Confidentiality Statement

This document and the information contained within are the property of **"Dalang Communication Technology Co., Ltd"**, and are for use only by authorized individuals for specific purposes. This document contains confidential information. Without explicit written permission from **"Dalang Communication Technology Co., Ltd"**, no person or group may copy, distribute, disseminate, display, or disclose this document or any part of it to a third party in any form. Recipients must strictly adhere to confidentiality obligations, protect the information in the document from being disclosed or misused, and ensure that all relevant personnel follow the same confidentiality rules. Individuals or organizations violating this statement will face legal prosecution and/or contractual penalties.

Thank you for your support and cooperation in protecting the confidential information of **"Dalang Communication Technology Co., Ltd"**.

Contents

1 Product Application Scenarios	1
Figure 1 Product Application Scenarios	1
2 Features	2
3 Structural Characteristic	3
Figure 2 Product structure diagram	3
Figure 3 Product correlation chart	3
Figure 4 Process flow diagram	3
4 Specifications	4
Table 1 Product Specifications	4
5 Product Photos	5
Figure 5 Product Images	5

1 Product Application Scenarios

Our company's AK530-E (25 * 25 * 4mm) doubly fed point built-in active antenna is an antenna design used for wireless communication systems. It combines the characteristics of doubly fed point antennas and active antennas, aiming to improve the performance and flexibility of wireless communication systems. Double fed point antenna is a common antenna structure with two feeding points. The dual feed point built-in active antenna has a wide range of applications in the field of wireless communication, including UAV, measurement, Internet, etc. It can effectively enhance signals and provide reliable and effective solutions for various applications through high gain and wide frequency band range. Refer to Figure 1 for details.



Figure 1 Product Application Scenarios

2 Features

In this chapter, we will delve into and comprehensively elaborate on the functionalities and operating principles of the AK152, detailing how it plays a pivotal role in various applications as follows:

1. **High gain and wide frequency band:** Antennas have high gain and a wide frequency band range, which can effectively improve the reception quality and coverage range of signals.
2. **Environmental compliance:** Compliant with RoHS (Restriction of Hazardous Substances Directive) requirements, ensuring that the product meets environmental performance standards and is suitable for the global market.
3. **Flexibility:** The design of the built-in active antenna in the doubly fed point can be optimized and adjusted according to specific application requirements. By adjusting the feeding point position, antenna size, and active component parameters, flexible control of antenna performance can be achieved.
4. **Compact design:** The design of built-in active antennas is usually more compact and occupies less space than traditional external antennas. This is very advantageous for applications in limited spaces, such as mobile devices, drones, etc.

3 Structural Characteristic

In this section, we will conduct an in-depth analysis of the product's design details, presenting its aesthetic features and precise interface specifications through detailed structural diagrams. This perspective aims to provide a comprehensive framework, thereby enhancing the understanding and perception of the product's architecture. Refer to Figure 2, Figure 3, Figure 4.

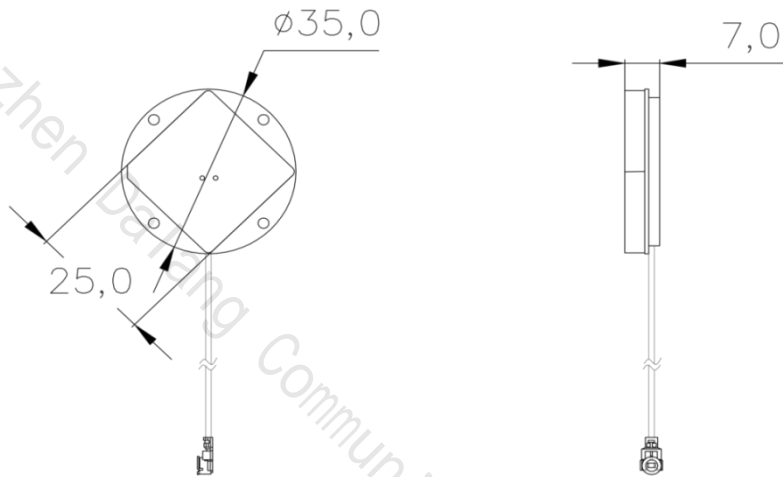

Figure 2 Product structure diagram



Figure 3 Product correlation chart

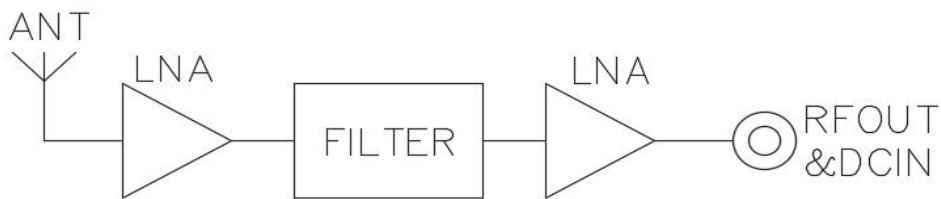

Figure 4 Process flow diagram

4 Specifications

In this section, we will provide a detailed list and explanation of the product's chip features, sensitivity, accuracy, operating principles, and other technical details, as detailed in Table 1.

Table 1 Product Specifications

Specification parameters			
Electrical characteristics	1	Usage frequency	GPS: L1 BDS: B1I GLONASS: G1 Galileo: E1
	2	Ceramic size	25*25*4
	3	impedance	50Ω
	4	Polarization mode	RHCP
	5	LNA GAIN @90°	L1:26±2dB
	6	LNA noise factor @+25 °C ± 5 ° TYP	<2.0
	7	LNA VSWR	2.0 MAX
	8	working voltage	3.3~5V
	9	electric current	10mA
Mbom	1	Overall size	35*35*7mm
	2	Product weight	13.8g
	3	joint	IPEX (customizable)
	4	wire rod	RG1.13 line (customizable)
	5	Line length	65mm (customizable)
	6	Installation method	Screw fixation
Environmental	1	operation temperature	-40°C~+85°C, 10%~95% RH
	2	storage temperature	-45°C~+85°C, 10%~95% RH
	3	humidity	10%~95%

5 Product Photos

In this chapter, we will showcase real-life images of the product, as shown in Figure 5. These images provide a detailed view of our product from various angles and perspectives. We believe that through authentic representation, we can better convey the value and concept of the product, thereby enhancing your trust and satisfaction.

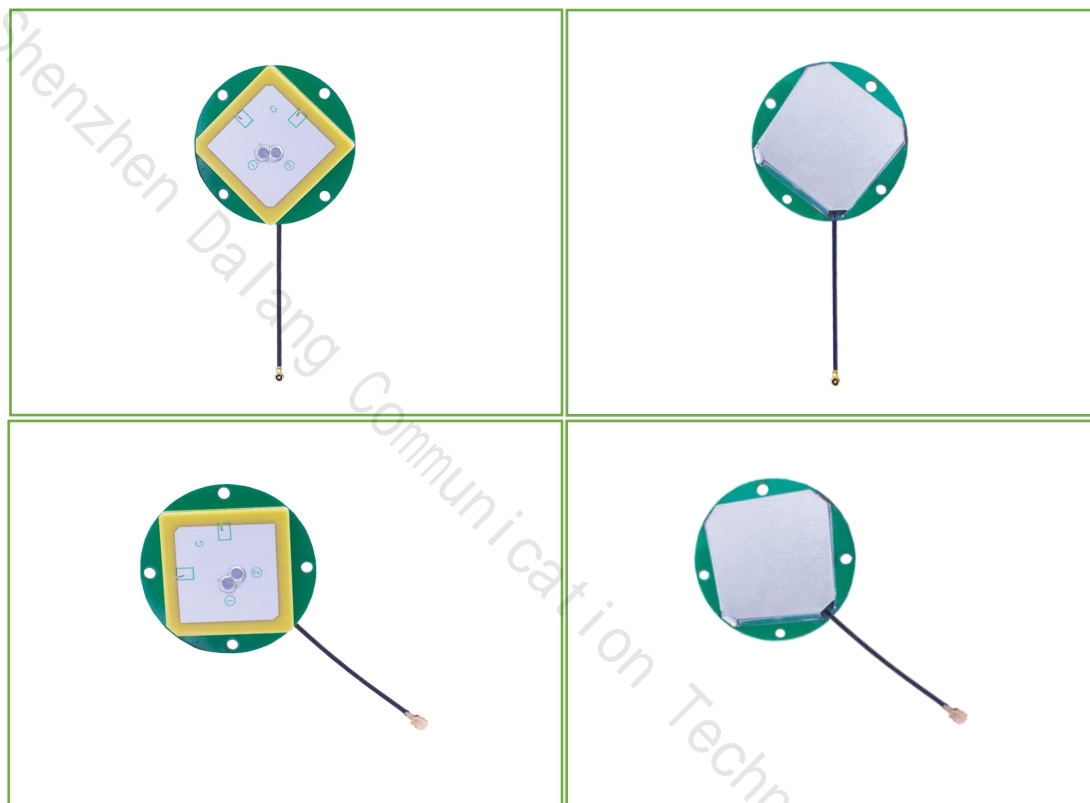

Figure 5 Product Images