



**AK211**





# Dalang Communication Technology Co., Ltd Product Specification

Product Name: GPS ANTENNA

Product Model: AK211

Version Number: V 1.0

Revision Date: 2025.03.03

# Confidentiality Statement

This document and the information contained within are the property of **"Dalang Communication Technology Co., Ltd"**, and are for use only by authorized individuals for specific purposes. This document contains confidential information. Without explicit written permission from **"Dalang Communication Technology Co., Ltd"**, no person or group may copy, distribute, disseminate, display, or disclose this document or any part of it to a third party in any form. Recipients must strictly adhere to confidentiality obligations, protect the information in the document from being disclosed or misused, and ensure that all relevant personnel follow the same confidentiality rules. Individuals or organizations violating this statement will face legal prosecution and/or contractual penalties.

Thank you for your support and cooperation in protecting the confidential information of **"Dalang Communication Technology Co., Ltd"**.

# Contents

1 Product Application Scenarios .....	1
Figure 1 Product Application Scenarios .....	1
2 Features .....	2
3 Structural Characteristic .....	3
Figure 2 Product structure diagram .....	3
Figure 3 Product correlation chart .....	3
Figure 4 Process flow diagram .....	3
4 Specifications .....	4
Table 1 Product Specifications .....	4
5 Product Photos .....	5
Figure 5 Product Images .....	5

# 1 Product Application Scenarios

Our company's AK211 single-layer ceramic (40 \* 40 \* 4) active antenna is equipped with a built-in low-noise amplifier, which can significantly improve signal gain, enhance reception sensitivity, and easily capture weak signals. At the same time, it can effectively compensate for losses during signal transmission, reduce signal attenuation, and operate stably in complex electromagnetic environments. This antenna is compact in size and easy to integrate into various devices that require strict space, helping devices achieve miniaturization and lightweight. And it has good frequency selectivity, can filter out interference signals, multi band support function can also meet the needs of different communication standards, and has a wide range of application scenarios. Refer to Figure 1 for details.



Figure 1 Product Application Scenarios

## 2 Features

In this chapter, we will delve into and comprehensively elaborate on the functionalities and operating principles of the AK211, detailing how it plays a pivotal role in various applications as follows:

1. **Excellent signal enhancement:** Equipped with an active circuit, it can significantly amplify weak signals, improve signal reception sensitivity and strength, and work stably even in complex environments.
2. **Compact structure:** The 40 \* 40 \* 4 passive antenna is built into it, occupying a small space and making it easy to install and integrate into various devices.
3. **Strong adaptability:** The equipped cables and interfaces can flexibly connect various devices and are widely used in fields such as navigation, communication, and the Internet of Things.
4. **Easy installation:** The cable length is appropriate, the interface connection operation is simple, and there is no need for complex installation processes and professional tools, which can save installation time and labor costs.
5. **Good anti-interference ability:** It has a certain degree of resistance to interference from other surrounding signals, can effectively filter out clutter, ensure the purity of output signals, and improve the accuracy of data transmission.

### 3 Structural Characteristic

In this section, we will conduct an in-depth analysis of the product's design details, presenting its aesthetic features and precise interface specifications through detailed structural diagrams. This perspective aims to provide a comprehensive framework, thereby enhancing the understanding and perception of the product's architecture. Refer to Figure 2, Figure 3, Figure 4.

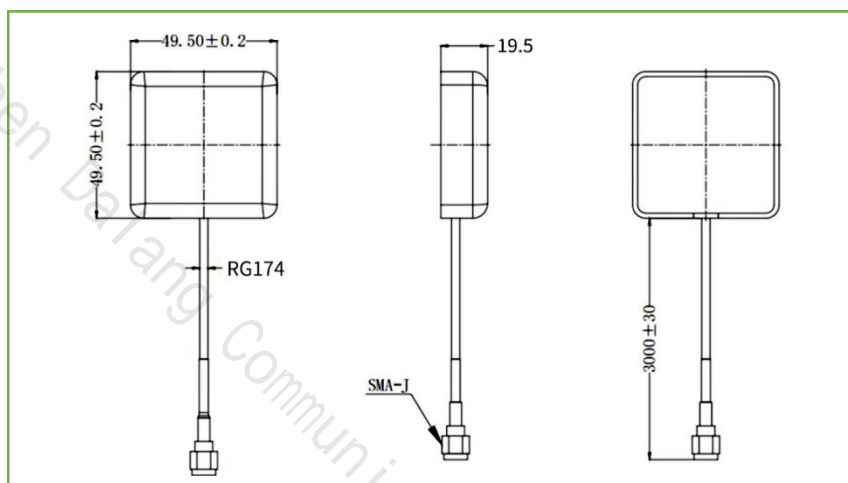

Figure 2 Product structure diagram



Figure 3 Product correlation chart



Figure 4 Process flow diagram

## 4 Specifications

In this section, we will provide a detailed list and explanation of the product's chip features, sensitivity, accuracy, operating principles, and other technical details, as detailed in Table 1.

Table 1 Product Specifications

Specification parameters			
<b>Antenna characteristics</b>	1	antenna model	GPS external antenna
	2	Ceramic size	40*40*4mm
	3	Usage frequency	GPS: L1:1575.42±1.023MHZ GLONASS: L1:1602+0.5625MHZ BDS: B1:1561±1.023MHZ GALILEO: E1:1575
	4	V.S.W.R	≤2.0
	5	-10dB bandwidth MHz min	10min
	6	Gain	28±2dBic
	7	impedance	50 Ω
	8	Polarization mode	RHCP
<b>LNA</b>	1	LNA gain	27±2dB
	2	V.S.W.R	<2
	3	figure	<1.5dB
	4	voltage	DC 3~5V
	5	electric current	<20mA
	6	impedance	50 Ω
<b>mbom</b>	1	Overall size (mm)	49.5*49.5*19.5mm
	2	Product weight	76.6g
	3	joint	SMA elbow (customizable)
	4	wire rod	RG174 (customizable)
	5	Line length	3m (customizable)
	6	PCB	FR4
<b>work environment</b>	1	work environment	-40°C~+85°C, 10%~95%RH
	2	Environment	-55°C+100°C, 10%95%RH

## 5 Product Photos

In this chapter, we will showcase real-life images of the product, as shown in Figure 5. These images provide a detailed view of our product from various angles and perspectives. We believe that through authentic representation, we can better convey the value and concept of the product, thereby enhancing your trust and satisfaction.



Figure 5 Product Images