

Dalang

AK203





Dalang Communication Technology Co., Ltd Product Specification

Product Name: GNSS Antenna

Product Model: AK203

Version Number: V 1.0

Revision Date: 2025.05.14

Confidentiality Statement

This document and the information contained within are the property of **"Dalang Communication Technology Co., Ltd"**, and are for use only by authorized individuals for specific purposes. This document contains confidential information. Without explicit written permission from **"Dalang Communication Technology Co., Ltd"**, no person or group may copy, distribute, disseminate, display, or disclose this document or any part of it to a third party in any form. Recipients must strictly adhere to confidentiality obligations, protect the information in the document from being disclosed or misused, and ensure that all relevant personnel follow the same confidentiality rules. Individuals or organizations violating this statement will face legal prosecution and/or contractual penalties.

Thank you for your support and cooperation in protecting the confidential information of **"Dalang Communication Technology Co., Ltd"**.

Contents

1 Product Application Scenarios	1
Figure 1 Product Application Scenarios	1
2 Features	2
3 Structural Characteristic	3
Figure 2 Product structure diagram	3
Figure 3 Product correlation chart	3
Figure 4 Process flow diagram	3
4 Specifications	4
Table 1 Product Specifications	4
5 Product Photos	6
Figure 5 Product Images	6

1 Product Application Scenarios

Our company's AK203 high-performance external antenna adopts advanced stacked ceramic antenna design, integrating L1+L5 dual band receiving capability, specially designed for high-precision positioning and navigation applications. By incorporating a multi-layer ceramic structure, the antenna achieves excellent multi band signal capture performance in a compact size. Combined with the gain advantage of an external antenna, it significantly improves signal reception strength and stability, making it suitable for high demand scenarios such as drones, surveying equipment, in car navigation, and intelligent transportation. Refer to Figure 1 for details.



Figure 1 Product Application Scenarios

2 Features

In this chapter, we will delve into and comprehensively elaborate on the functionalities and operating principles of the AK203, detailing how it plays a pivotal role in various applications as follows:

1. Dual frequency high-precision positioning: synchronously supports L1/L5 frequency bands, compatible with GPS/Beidou/GLONASS/Galileo multiple systems, achieving centimeter level RTK positioning;

2. Stacked ceramic antenna: Designed with a 25 * 25 * 4/35 * 35 * 4 stacked ceramic structure, it has ultra-high sensitivity to ensure stable signal reception in complex environments;

3. High performance signal processing: External high gain design combined with low noise amplifier (LNA) significantly improves signal-to-noise ratio and positioning speed;

4. Lightweight and easy to install: Compact and lightweight design, supporting multiple installation methods such as magnetic suction/screws, suitable for various mobile devices.

5. Industrial noise reduction: Adopting industrial grade low-noise RF circuit design, it enhances the ability to resist multipath interference and ensures clear signal acquisition even in high noise environments.

3 Structural Characteristic

In this section, we will conduct an in-depth analysis of the product's design details, presenting its aesthetic features and precise interface specifications through detailed structural diagrams. This perspective aims to provide a comprehensive framework, thereby enhancing the understanding and perception of the product's architecture. Refer to Figure 2, Figure 3, Figure 4.

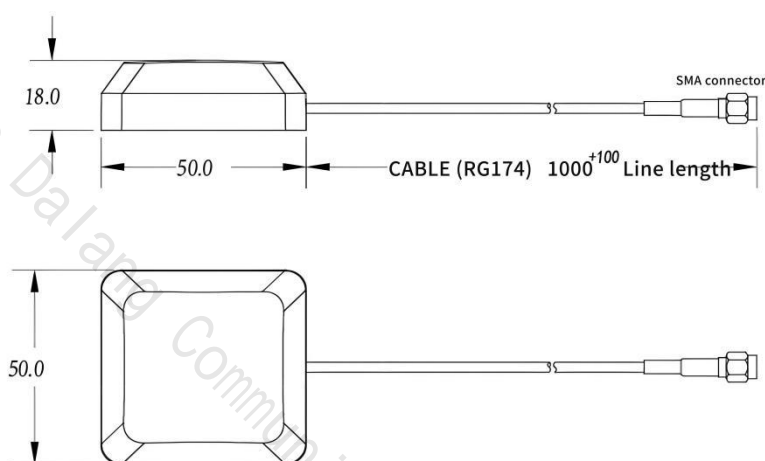

Figure 2 Product structure diagram



Figure 3 Product correlation chart



Figure 4 Process flow diagram

4 Specifications

In this section, we will provide a detailed list and explanation of the product's chip features, sensitivity, accuracy, operating principles, and other technical details, as detailed in Table 1.

Table 1 Product Specifications

Specification parameters			
Antenna parameters	1	Antenna name	GNSS antenna
	2	Ceramic size (mm)	25*25*4/35*35*4
	3	Usage frequency	GPS: L1: 1575.42±1.023MHz, L5: 1176.45±1.023MHz GLONASS: L1:1602+0.5625*K(MHz) BDS: B1: 1561±1.023MHz GALILEO: E1: 1575
	5	gain	L1:5 ± 1dBi L5:3 ± 1dBi
	6	V.S.W.R	≤2
	7	Minimum -10dB bandwidth (MHz)	10min
	8	impedance	50 Ω
	9	Polarization mode	RHCP
	10	tcf	20ppm/deg. °C max
	LAN	1	Gain (Gain)
2		figure	<1dB
3		VSWR	<2.0
4		output vswr	<2.0
5		voltage	DC 3~5V
6		electric current	15~25mA
7		impedance	50 Ω

Physical parameters	1	Overall size	50*18mm
	2	weight	69.8g
	3	Line type	RG174
	4	Line length	L=1m
	5	Linear interface	SMA

Shenzhen Dalang Communication Technology Co., Ltd

5 Product Photos

In this chapter, we will showcase real-life images of the product, as shown in Figure 5. These images provide a detailed view of our product from various angles and perspectives. We believe that through authentic representation, we can better convey the value and concept of the product, thereby enhancing your trust and satisfaction.



Figure 5 Product Images