

# Dalang

## AK161





# Dalang Communication Technology Co., Ltd Product Specification

Product Name:	GNSS Antenna
Product Model:	AK161
Version Number:	V 1.0
Revision Date:	2024.06.04

# Confidentiality Statement

This document and the information contained within are the property of **"Dalang Communication Technology Co., Ltd"**, and are for use only by authorized individuals for specific purposes. This document contains confidential information. Without explicit written permission from **"Dalang Communication Technology Co., Ltd"**, no person or group may copy, distribute, disseminate, display, or disclose this document or any part of it to a third party in any form. Recipients must strictly adhere to confidentiality obligations, protect the information in the document from being disclosed or misused, and ensure that all relevant personnel follow the same confidentiality rules. Individuals or organizations violating this statement will face legal prosecution and/or contractual penalties.

Thank you for your support and cooperation in protecting the confidential information of **"Dalang Communication Technology Co., Ltd"**.

# Contents

1 Product Application Scenarios .....	1
Figure 1 Product Application Scenarios .....	1
2 Features .....	2
3 Structural Characteristic .....	3
Figure 2 Product structure diagram .....	3
Figure 3 Product correlation chart .....	3
Figure 4 Process flow diagram .....	3
4 Specifications .....	4
Table 1 Product Specifications .....	4
5 Product Photos .....	6
Figure 5 Product Images .....	6

# 1 Product Application Scenarios

The AK161-GNSS antenna features advanced quad-arm coupling and four-feed point technology, supporting Bei Dou, GPS, GLONASS, and GALILEO across L1, L2, and L5 bands. Equipped with a Low Noise Amplifier (LNA), it enhances signal quality, making it ideal for high-precision and multi-system GNSS applications in geomatics, precision agriculture, and vehicle navigation. See Figure 1 for details.



Figure 1 Product Application Scenarios

## 2 Features

In this chapter, we will delve into and comprehensively elaborate on the functionalities and operating principles of the AK161, detailing how it plays a pivotal role in various applications as follows:

1. **Multi-arm spiral technology:** The antenna uses a multi-arm spiral design to ensure efficient right-hand circular polarization, optimizing signal reception and maintaining a stable signal phase center. This design reduces the impact of measurement errors, enhancing positioning accuracy and reliability.
2. **High gain and gain roll-off performance:** The antenna unit not only has high gain characteristics but also maintains minimal gain roll-off. This means the antenna can still perform well when receiving signals from satellites at low elevation angles, enhancing the overall stability and coverage of the signal.
3. **Low noise and high gain amplifier:** The intricate amplifier design, combined with excellent out-of-band suppression, effectively reduces background noise while enhancing the strength of the desired signal. This makes the antenna more effective in receiving weak signals, especially in environments with significant signal interference.
4. **Compact and lightweight:** The antenna is small and light, making it easy to carry and install. This makes it particularly suitable for applications that require mobility or rapid deployment at multiple locations.

### 3 Structural Characteristic

In this section, we will conduct an in-depth analysis of the product's design details, presenting its aesthetic features and precise interface specifications through detailed structural diagrams. This perspective aims to provide a comprehensive framework, thereby enhancing the understanding and perception of the product's architecture. Refer to Figure 2, Figure 3, Figure 4.

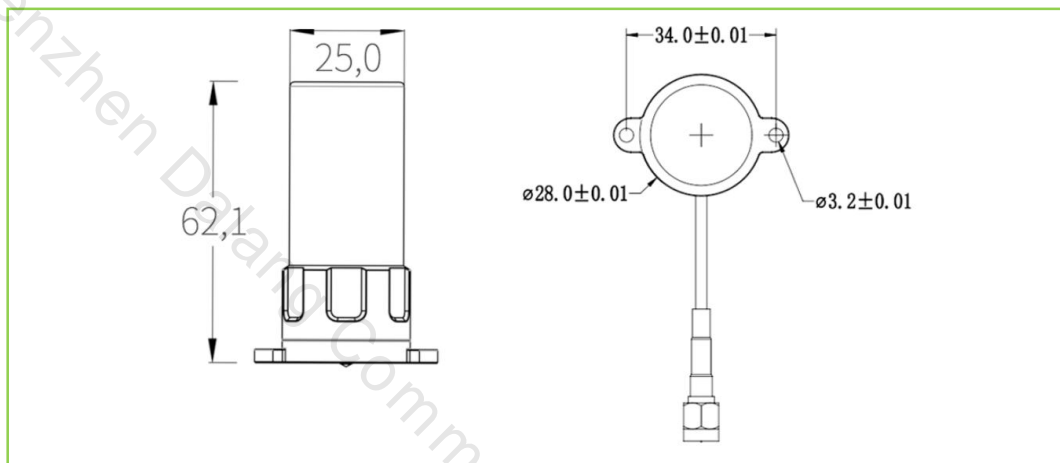

Figure 2 Product structure diagram



Figure 3 Product correlation chart

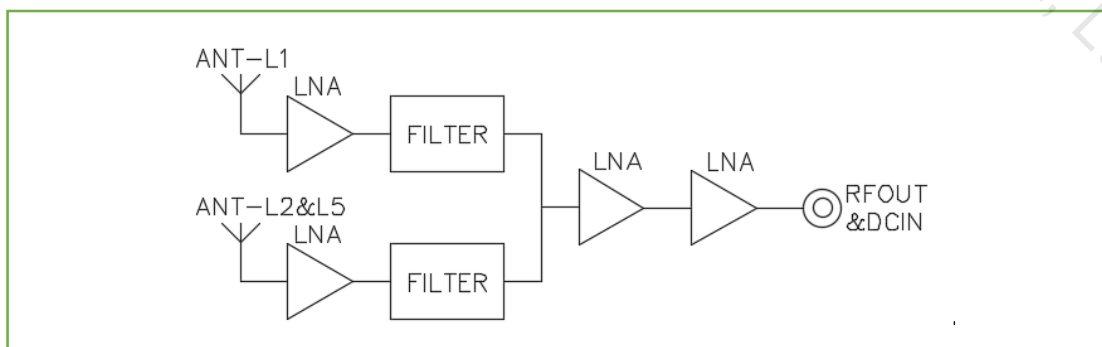

Figure 4 Process flow diagram

## 4 Specifications

In this section, we will provide a detailed list and explanation of the product's chip features, sensitivity, accuracy, operating principles, and other technical details, as detailed in Table 1.

Table 1 Product Specifications

Specifications			
Antenna characteristics	1	Operating frequency	GPS: L1:1575.42+1.023MHz. L2:1227+1.023MHz, L5:1176+1.023MHz 北斗: B1:1561+2.046MHz, B2:1207 +2.046MHz. B3:1268+10.23MHz. GLONASS L1=1602+0.5625*k(MHz) L2=1246+0.4375*k(MHz), GALILE: E1: 1575
	2	Antenna specifications	GPS, BDS, GLONASS,GALILEO
	3	Frequency rang	1176-1278/1559-1612MHz
	4	V.S.W.R	$\leq 2.0$
	5	Axial Ratio	At elevation angle 90 degrees: $\leq 3$ , at elevation angle 15 degrees: $\leq 5$
	6	Gain	At an elevation angle of 90 degrees: $\geq 6$ , at an elevation angle of 20 degrees: $\geq 0$ plane
	7	Front to back Power	$\pm 60$ degrees $\geq 15$ dB
	8	Phase center (mm)	$< 2$
	9	Impedence	50 $\Omega$
	10	Polarization	RHCP
LNA	1	LNA GAIN	38 $\pm$ 2dB
	2	V.S.W. R	2.0

	3	In-band flatness	±2dB
	4	Noise Figure	<2.0
	5	DC Voltage	3.3~16V
	6	Current	<35 mA
<b>Mechanical structure</b>	1	Component name	SPEC
	2	Antenna	Four arm spiral
	3	Installation method	Through connector
	4	Antenna dimensions	Φ62.1*25mm
	5	Product weight	25.4g
	6	RF output interface	SMA-J (Inner screw inner pin)
	7	Antenna housing	ABS+PC
	8	Line type	RG316
	9	Line length	150mm(Customizable)
<b>Environmental characteristics</b>	1	Operating temperature	-40°C~+85°C, 10%~95% RH
	2	Storage temperature	-55°C~+100°C, 10%~95% RH
	3	Vibration	Sine sweep @1.5mmAM 10~55Hz each Axis

## 5 Product Photos

In this chapter, we will showcase real-life images of the product, as shown in Figure 5. These images provide a detailed view of our product from various angles and perspectives. We believe that through authentic representation, we can better convey the value and concept of the product, thereby enhancing your trust and satisfaction.



Figure 5 Product Images