

# DaLang

## AK159





# DaLang Communication Technology Co., Ltd. Product Specification

Product Name:	GNSS spiral antenna
Product Model:	AK159
Version Number:	V 1.0
Revision Date:	2024.9.28

# Confidentiality Statement

This document and the information contained within are the property of "**Dalang Communication Technology Co., Ltd**", and are for use only by authorized individuals for specific purposes. This document contains confidential information. Without explicit written permission from "**Dalang Communication Technology Co., Ltd**", no person or group may copy, distribute, disseminate, display, or disclose this document or any part of it to a third party in any form. Recipients must strictly adhere to confidentiality obligations, protect the information in the document from being disclosed or misused, and ensure that all relevant personnel follow the same confidentiality rules. Individuals or organizations violating this statement will face legal prosecution and/or contractual penalties.

Thank you for your support and cooperation in protecting the confidential information of "**Dalang Communication Technology Co., Ltd**".

# Contents

1 Product Application Scenarios .....	1
Figure 1 Product Application Scenarios .....	1
2 Features .....	2
3 Structural Characteristic .....	3
Figure 2 Product structure diagram .....	3
Figure 3 Product correlation chart .....	3
Figure 4 Process flow diagram .....	3
4 Specifications .....	4
Table 1 Product Specifications .....	4
5 Product Photos .....	6
Figure 5 Product Images .....	6

Shenzhen Dalang Communication Technology Co., Ltd

# 1 Product Application Scenarios

The AK159 GNSS antenna is a high-performance device with advanced eight-arm coupling and four-feed point technology. It supports Beidou, GPS, GLONASS, and GALILEO systems, receiving L1, L2, and L5 signals. With a built-in low-noise amplifier (LNA) and dualstage filter system, it enhances signal quality and clarity, excelling in anti-interference. Ideal for high-precision and multi-system applications like geodetic surveying, precision agriculture, and vehicle navigation. See Figure 1 for details.



Figure 1 Product Application Scenarios

## 2 Features

In this chapter, we will delve into and comprehensively elaborate on the functionalities and operating principles of the AK159, detailing how it plays a pivotal role in various applications as follows:

1. **Multi-Arm Helix Technology:** The antenna features a multi-arm helix design, ensuring efficient right-hand circular polarization, optimizing signal reception, and maintaining phase center stability. This reduces measurement errors, enhancing positioning accuracy and reliability.
2. **High Gain and Gain Roll-Off Performance:** The antenna unit boasts high gain characteristics with minimal gain roll-off, meaning it can maintain good reception even for low-elevation satellite signals, improving overall signal stability and coverage.
3. **Low Noise and High Gain Amplifier:** The sophisticated amplifier design, combined with excellent out-of-band suppression, effectively reduces background noise while enhancing the desired signal strength, making the antenna more effective in receiving weak signals, especially in high-interference environments.
4. **Compact and Lightweight:** The antenna's small size and light weight make it easy to carry and install, ideal for applications requiring mobility or rapid deployment in multiple locations.
5. **Compact structure:** Compared with other types of high gain antennas, the four arm spiral antenna can be designed to be more compact, small in size, light in weight, easy to install and carry, and suitable for applications with limited space, such as drones, handheld devices, satellite terminals, and other scenarios that have strict requirements for device size and weight

### 3 Structural Characteristic

In this section, we will conduct an in-depth analysis of the product's design details, presenting its aesthetic features and precise interface specifications through detailed structural diagrams. This perspective aims to provide a comprehensive framework, thereby enhancing the understanding and perception of the product's architecture. Refer to Figure 2, Figure 3

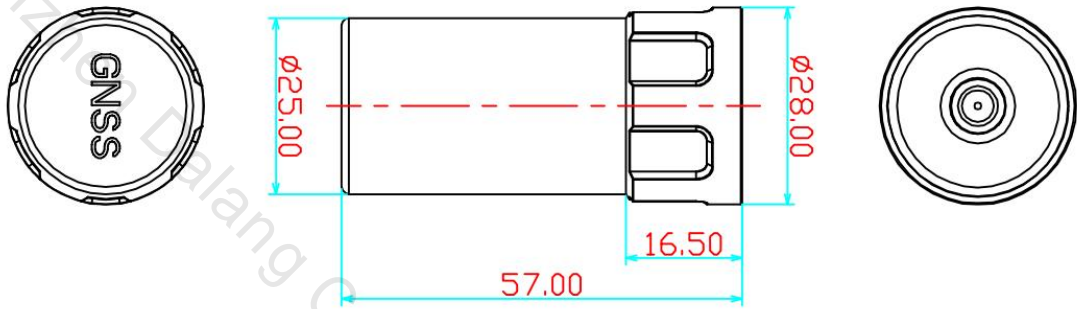

Figure 2 Product structure diagram



Figure 3 Product correlation chart

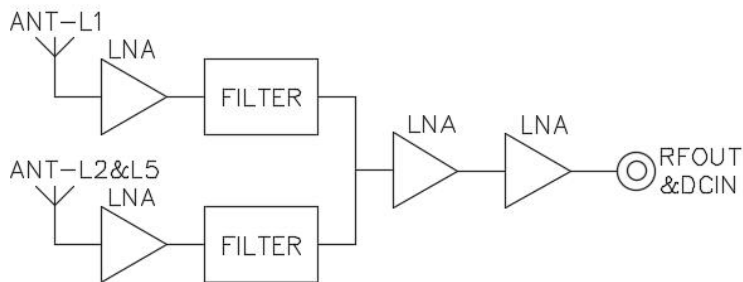

Figure 4 Process flow diagram

## 4 Specifications

In this section, we will provide a detailed list and explanation of the product's chip features, sensitivity, accuracy, operating principles, and other technical details, as detailed in Table 1.

Table 1 Product Specifications

Specification parameters			
Antenna characteristics	1	working frequency	GPS: L1:1575.42+1.023MHz. L2:1227+1.023MHz, L5:1176+1.023MHz 北斗: B1:1561+2.046MHz, B2:1207 +2.046MHz. B3:1268+10.23MHz. GLONASS L1=1602+0.5625*k(MHz) L2=1246+0.4375*k(MHz), GALILE: E1: 1575
	2	frequency range	1176-1278/1559-1612MHz
	3	V. S.W.R (standing wave ratio)	$\leq 2.0$
	4	Axis ratio	Elevation angle of 90 degrees: $\leq 3$ , elevation angle of 15 degrees: $\leq$ five
	5	gain	Elevation angle of 90 degrees: $\geq 6$ , elevation angle of 20 degrees: $\geq 0$ dB
	6	Before and after comparison	$\pm 60$ degrees $\geq 15$ dB
	7	Phase center (mm)	$< 2$
	8	impedance	50 $\Omega$
	9	Polarization mode	RHCP
	10	Out of band inhibition	1268+100MHZ $\geq 50$ db, 1170-100MHZ $\geq 50$ db, 1602+100MHZ $\geq 50$ db,

			1561-100MHZ $\geq$ 50db.
<b>LNA</b>	1	LNA gain	38 $\pm$ 2dB
	2	V. S.W.R (standing wave ratio)	<2
	3	Flatness within the band	$\pm$ 2dB
	4	Noise coefficient	<2.0
	5	DC power supply	3.3~5.5V
	6	Working current	<35 mA
<b>Mechanical structure</b>	1	Component Name	SPEC
	2	Installation method	Threaded connection
	3	Antenna size	$\Phi$ 57*28mm
	4	Product weight	16g
	5	RF output interface	SMA(internal spiral pattern needle)
	6	Antenna casing	ABS+PC
<b>Environmental</b>	1	working temperature	-40 $^{\circ}$ C~+85 $^{\circ}$ C, 10%~95% RH
	2	Storage temperature	-55 $^{\circ}$ C~+100 $^{\circ}$ C, 10%~95% RH
	3	shock	Sine scan @ 1.5mm AM, 10~55Hz per axis

## 5 Product Photos

In this chapter, we will showcase real-life images of the product, as shown in Figure 5. These images provide a detailed view of our product from various angles and perspectives. We believe that through authentic representation, we can better convey the value and concept of the product, thereby enhancing your trust and satisfaction.



Figure 5 Product Images