

Dalang

UB982





Dalang Communication Technology Co., Ltd Product Specification

Product Name:	Circuit Board
Product Model:	UB982
Version Number:	V 1.0
Revision Date:	2024.04.02

Confidentiality Statement

This document and the information contained within are the property of **Dalang Communication Technology Co., Ltd**, and are for use only by authorized individuals for specific purposes. This document contains confidential information. Without explicit written permission from **Dalang Communication Technology Co., Ltd**, no person or group may copy, distribute, disseminate, display, or disclose this document or any part of it to a third party in any form. Recipients must strictly adhere to confidentiality obligations, protect the information in the document from being disclosed or misused, and ensure that all relevant personnel follow the same confidentiality rules. Individuals or organizations violating this statement will face legal prosecution and/or contractual penalties.

Thank you for your support and cooperation in protecting the confidential information of "**Dalang Communication Technology Co., Ltd**."

Table of Contents

1	Product Application Scenarios.....	1
	Figure 1 Product Application Scenarios.....	1
2	Features.....	2
3	Structural Characteristic.....	3
	Figure 2 Dimensional Drawing (in millimeters).....	3
	Table 1 PIN Functionality.....	3
	Table 2 Interface Characteristics.....	4
4	Specifications.....	5
	Table 3 Product Specifications.....	5
5	Product Photos.....	7
	Figure 3 Product Images.....	7
6	Common Configuration Instructions.....	8
7	Common message parsing.....	9
	1、 GPGGA (Longitude and latitude coordinate information).....	9
	2、 GPRMC data analysis.....	10
	3、 GPNTR (distance information from reference station).....	11
	4. GPVTG (Ground Velocity Information).....	12
	5、 GPGSV statement (visible satellite information).....	13
	6、 GPGSA statement (precision factor, satellite information).....	14
	7、 GPTRA (azimuth information) requires dual antennas.....	15
	8、 Headinga requires dual antennas for azimuth information.....	16
	9、 Bestposa(Position coordinate information).....	18
8	Typical Applications.....	19
	8.1 Application of high-precision positioning for medium and short distances.....	19
	8.2 Application of Medium to Long Range High Precision Positioning.....	20
	8.3 High precision positioning application without reference station.....	21

1 Product Application Scenarios

The AK314-UB982 module is an ultra-low-cost, low-power, and high-performance real-time kinematic (RTK) positioning module, utilizing a full-system, full-frequency RTK engine. It provides real-time centimeter-level accuracy, making it ideal for use in drones, automotive, and surveying applications. The module supports both rover and base station modes, employing carrier phase differential technology to reduce various measurement errors and achieve high-precision positioning. In base station mode, it outputs RTCM2.x/3.x data streams compatible with most commercial rover stations, while in rover mode, it can connect to various base stations or enhancement systems. With static positioning accuracy below 1cm, dynamic accuracy below 2cm, and an output rate of 1~20Hz, this module is highly cost-effective and suitable for a wide range of applications, as illustrated in Figure 1.



Figure 1 Product Application Scenarios

2 Features

This chapter explores and thoroughly explains the functionalities and working principles of the AK314-UB982, detailing its key role in various applications:

1. **Technological Advancement:** Based on the UB982 series product design, it supports full-frequency RTK positioning and dual antennas.
2. **Multi-System Frequency Support:** Highly compatible and flexible, it can receive and process signals from multiple satellite navigation systems like BDS, GPS, GLONASS, Galileo, QZSS, and SBAS, enhancing global coverage and accuracy.◦
3. **Quad-Mode Combined RTK Calculation:** Exhibits excellent integration and rapid positioning initialization, ensuring speed and accuracy in various conditions.◦
4. **Dual-RTK Technology:** Enhances signal processing redundancy and stability with dual RTK engines and dual antenna inputs, improving positioning reliability and precision.◦
5. **20Hz Data Output Rate:** Shows high-performance processing capability, quickly responding to dynamic changes, ideal for applications like drones that need fast positioning updates.◦
6. **Base Station or Rover Configuration:** Offers great application flexibility, adjusting modes based on scenario needs.◦
7. **Differential Positioning and Vector Attitude Mode:** Provides multifunctionality for precise location and orientation, meeting complex navigation requirements.◦
8. **Compatibility with Flight Control Systems:** Like Pixhawk and APM, showing strong integration ability for seamless connection to existing flight platforms.◦
9. **Quad-Arm Helix Antenna Design:** Features lightweight, high-gain attributes, enhancing signal reception and anti-interference capability, ensuring stable and accurate positioning.◦
10. **Industrial-Grade Low Noise RF Circuit:** Demonstrates powerful signal processing, effectively reducing multipath interference, ensuring signal clarity and positioning accuracy.◦

3 Structural Characteristic

This section presents and analyzes the product's design details, illustrated through comprehensive images to depict its exterior features. These views offer a complete perspective to understand the product's structure, detailed in Figure 2, Table 1 and Table 2.

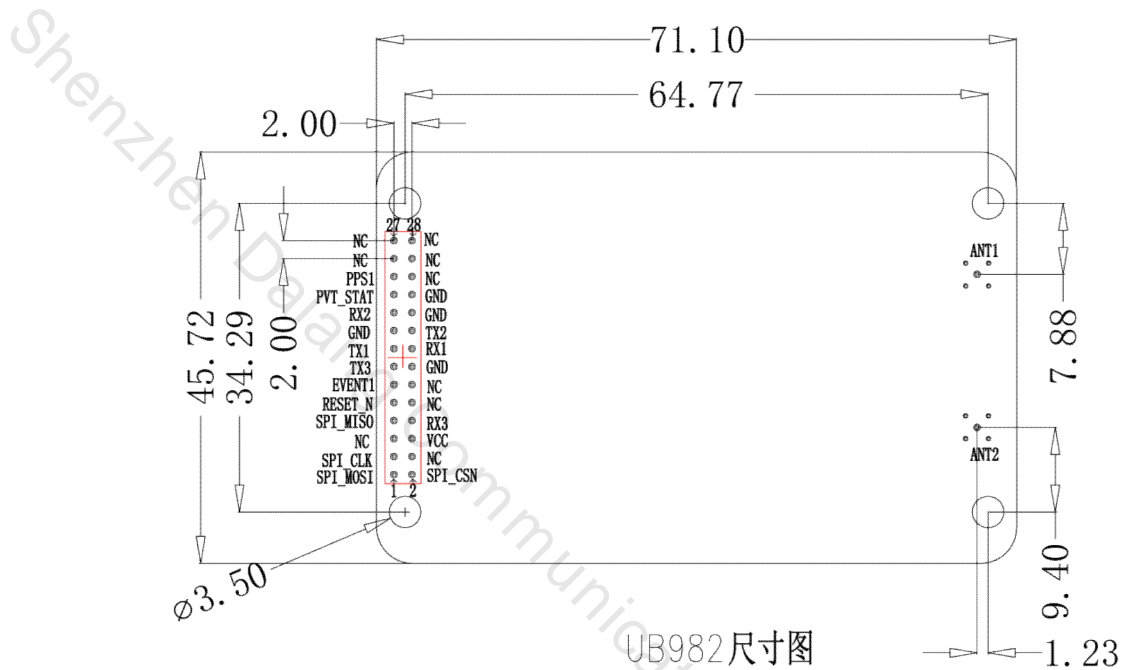

Figure 2 Dimensional Drawing (in millimeters)

Table 1 PIN Functionality

NO.	Signal Name	Signal Description
1	SPI_MOSI	SPI Master Out Slave In data input
2	SPI_CSN	SPI Chip Select input
3	SPI_CLK	SPI Clock input
4	NC	No connection (internal)
5	NC	No connection (internal)
6	VCC	Power input, DC+5V
7	SPI_MISO	SPI Master In Slave Out data output
8	RX3	UART 3 receive, can be repurposed as CAN RXD, 3.3VTTL
9	RESET_N	System reset, active low
10	NC	No connection (internal)

11	EVENT1	Event trigger 1
12	NC	No connection (internal)
13	TX3	UART 3 transmit, can be repurposed as CAN TXD, 3.3VTTL
14	GND	Ground
15	TX1	UART 1 transmit, 3.3VTTL
16	RX1	UART 1 receive, 3.3VTTL
17	GND	Ground
18	TX2	UART 2 transmit, 3.3VTTL
19	RX2	UART 2 receive, 3.3VTTL
20	GND	Ground
21	PVT_STAT	PVT (Position, Velocity, Time) status indicator, outputs high when module can position, low otherwise
22	GND	Ground
23	PPS1	Pulse Per Second 1
24	NC	No connection (internal)
25	NC	No connection (internal)
26	NC	No connection (internal)
27	NC	No connection (internal)
28	NC	No connection (internal)

Table 2 Interface Characteristics

NO.	Name	Symbol	Min	Typical	Max	Unit
1	Main Power	VCC	2.7	3.3	5.0	V
2	Backup Power	V _{BAT}	1.4	3.3	3.6	V
3	RF Port Power	V _{RF}	3.0	3.1	3.3	V
4	High Level Input	V _{IH}	2.0			V
5	Low Level Input	V _{IL}			0.7	V
6	High Level Output	V _{OH}	3.2			V
7	Low Level Output	V _{OL}			0.1	V
8	Main UART Baud Rate	Baud		115200		bps
9	Differential Baud Rate	Baud		115200		bps

4 Specifications

Detailed specifications, chip features, sensitivity, accuracy, working principles, and other technical details of the product are listed and explained in this section, as shown in Table 3.

Table 3 Product Specifications

	chip	UM982			
Chip characteristics	Working mode	BDS: B1I、B2I、B3I GPS: L1C/A、L2P (Y)、L2C、L5 GLONASS: L1、L2 Galileo: E1、E5a、E5b QZSS: L1、L2、L5			
	Receiving channel	1408 channel			
Accuracy	Single point positioning (RMS)	Plane: 1.5m			
		Elevation: 2.5m			
	DGPS(RMS)	Plane: 0.4m			
		Elevation: 0.8m			
	RTK(RMS)	Flat: 0.8cm+1ppm			
		Elevation: 1.5cm+1ppm			
	Directional accuracy (RMS)	0.2 degrees/1m baseline			
	Time accuracy (RMS)	20 ns			
	Speed accuracy (RMS)	0.2 m/s			
	Observation accuracy (RMS)	BDS	GPS	GLONASS	Galileo
	B1I/B1C/L1 C/A/E1/G1 pseudorange	10cm	10cm	10cm	10cm
	B1I/B1C/ L1 C/A/E1/G1 Carrier Phase	1mm	1mm	1mm	1mm
	B3I/L2P(Y)/L2C/G2 pseudorange	10cm	10cm	10cm	10cm
B3I/L2P(Y)/L2C/G2 Carrier Phase	1mm	1mm	1mm	1mm	
B2I/ L5/E5a/E5b pseudorange	10cm	10cm	10cm	10cm	
B2I/ L5/E5a/E5b Carrier Phase	1mm	1mm	1mm	1mm	
Time To First	cold boot < 20 s				

Fix TTFF	Initialization time	<5s (Typical values)
	Initialize reliability	>99.9%
Output data	Baud rate	115200bps (default) [Optional: 4800-921600]
	Output interface	TTL/USB
	Output Protocol	NMEA0183、RTCM 3.3
	Data update rate	1Hz-20Hz (default 1Hz)
	Differential data	RTCM 3.3/3.2/3.1/3.0
	Carrier phase output	Support, output RAWX statement
	FLASH	built-in
Electrical specifications	working voltage	3~5.5V DC
	power waste	<800mW
Physical parameters	size	71.1*45.72mm
	weight	14.6g
	Connector	2x14 dual-row pins
	Antenna connector	MMCX*2
Environment	working temperature	-35°C-80°C
	Storage temperature	-40°C-85°C

5 Product Photos

In this section, real photos of the product are shown, providing different angles and details to convey the product's value and philosophy, thus enhancing trust and satisfaction with the product, as seen in Figure 3.

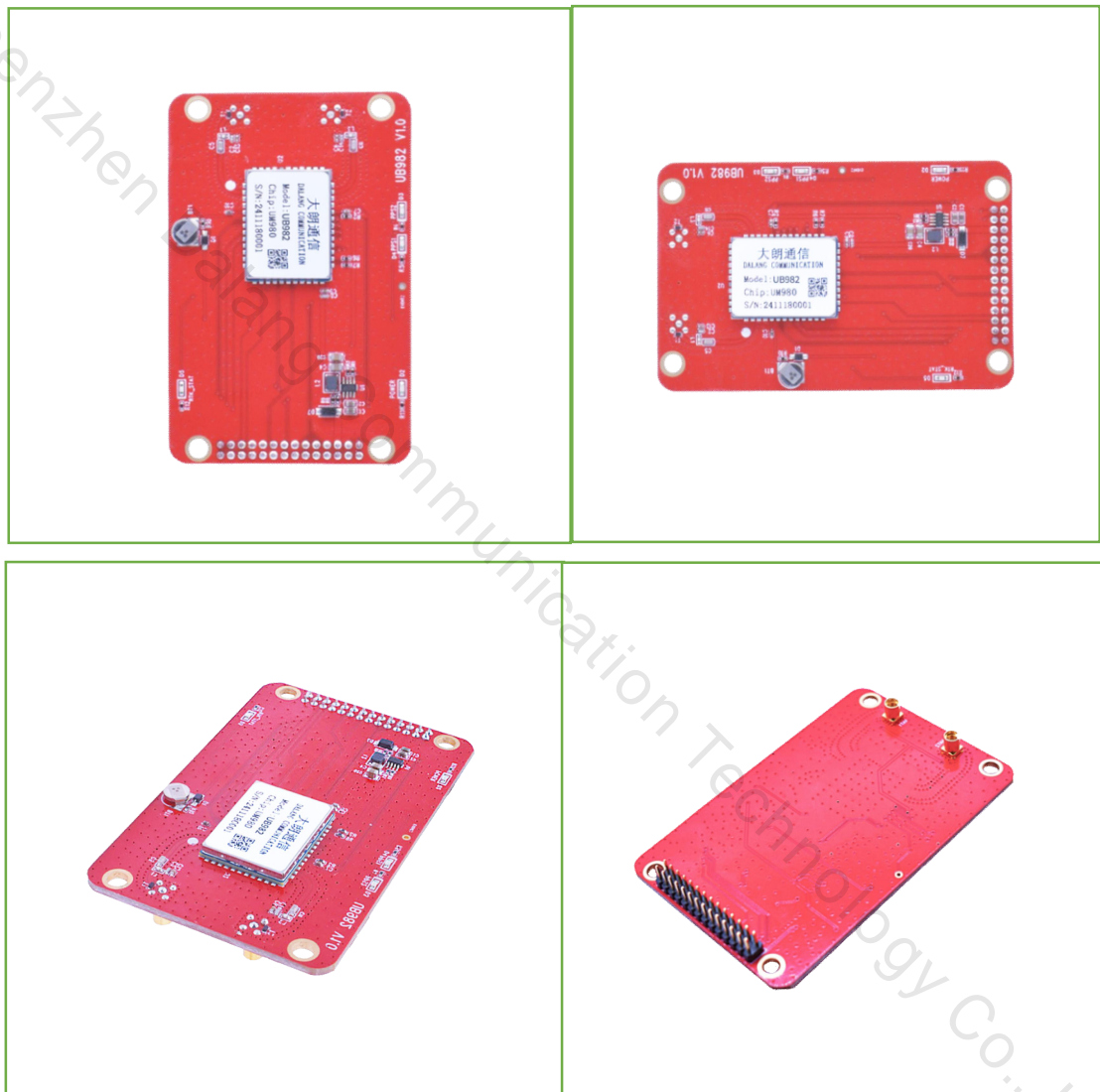

Figure 3 Product Images

6 Common Configuration Instructions

NO.	Instruction content	Function Description	Notes
1	VERSIONA	Version query	
2	CONFIG	Query receiver configuration	
3	SAVECONFIG	Save configuration	After configuring the receiver, a save command needs to be sent, otherwise the receiver will return to its factory state after being powered on again
4	CONFIG COM1 115200	Configure COM1 baud rate to 115200	
5	UNLOG	Stop all information output from the current serial port	
6	UNLOG COM1	Stop all output from COM1 serial port	This command can be sent on any serial port
7	UNLOG COM2 GPGGA	Stop COM2 serial port output of GPGGA data	If no serial port number is added, it will be the current serial port
8	GPGGA COM1 1	Output GGA data on COM1 serial port	If COM1 (such as GPGGA 1) is not in put, it will be the current serial port. If you want to output other data, such as "GSV", simply change the "GGA" in the instruction to "GSV" (the output information includes DTM, GBS, GGA, GLL, GNS, GRS, GSA, GST, GSV, THS, RMC, ROT, VTG, ZDA)
9	GPGGAH 1	Output satellite positioning GGA data calculated from the antenna from the current serial port	UM982 dual antenna module is only supported
10	freset	Restore factory settings	Note: The factory set baud rate is 115200
11	mode base	Set as reference station	
12	mode rover	Set as mobile station	This instruction can switch the receiver from base station mode to mobile station mode
13	gpgga comx 1	Set 1Hz output GGA message	COMX can be specified as COM1 Either COM2 or COM3
14	gpths comx 1	Output current heading information	COMX can be specified as COM1 Either COM2 or COM4
15	freset mode base time 60 1.5 2.5 rtcm1006 comX 10 rtcm1033 comX 10 rtcm1074 comX 1 rtcm1124 comX 1 rtcm1084 comX 1 rtcm1094 comX 1 saveconfig	Configure base station mode	COMX can be specified as COM1 Either COM2 or COM3

7 Common message parsing

1、 GPGGA (Longitude and latitude coordinate information)

\$GPGGA,062938.00,3110.4700719,N,12123.2657056,E,1,25,0.6,58.9666,M,0.000,

M,99,AAAA*50

Data parsing:

\$GPGGA,hhmmss,llll.llllll,a,yyyyy.yyyyyyy,b,q,n,x.x,h.h,M,dd,xxxx*CC

NO.	Name	Describe	Symbol	Give an example
1	\$GPGGA	Log header		\$GPGGA
2	utc	UTC time (hour/minute/second)	hhmmss.ss	202134.00
3	lat	Latitude: -90~90 degrees	llll.llllll	3110.4693903
4	latdir	Latitude direction: N: North; S: south	a	N
5	lon	Longitude: -180~180 degrees	yyyyy.yyyyyy y	12123.2621695
6	londir	Longitude direction: E: East; W: west	b	W
7	QF	Solution state 0: Invalid solution; 1: Single point positioning solution; 2: Pseudorange difference; 4: Fixed solution; 5: Floating solution;	q	4
8	sat No.	number of satellites	n	14
9	hdop	Horizontal DOP value	x.x	1.0
10	alt	elevation	h.h	50.22
11	a-units	Elevation Units	M	M
14	age	Differential Delay	dd	1
15	stn ID	Base station number: 0000-1023, when operating alone: AAAA	xxxx	1
16	*xx	Checksum	*hh	
17	[CR][LF]	Sentence terminator		[CR][LF]

2、 GPRMC data analysis

\$GNRMC,064401.65,A,3110.4706987,N,12123.2653375,E,0.604,243.2,300713,0.0, W,A*3
E

Data example:

\$GPRMC,014350.00,A,3110.4854911,N,12123.9129278,E,0.029,108.5,010909,0.0,E
*57

NO.	Name	Describe	Symbol	Give an example
1	\$GPRMC	Log header		\$GPRMC
2	utc	UTC time (hour/minute/second)	hhmmss.ss	143550.00
3	Pos status	Solution status: A=effective positioning V=invalid positioning	A	A
4	lat	Latitude: -90~90 degrees	llll.llllll	3110.4854911
5	latdir	Latitude direction: N: North; S: south	a	N
6	lon	Longitude: -180~180 degrees	yyyyy.yyyyyyy	12123.9129278
7	londir	Longitude direction: E: East; W: west	b	E
8	SPEED IN	Ground speed	q	0.29
9	Track Ture	Ground heading angle	n	108.5
10	Date	UTC date	ddmmyy	010909
11	Mag var	Magnetic declination (000.0~180.0 degrees, if the leading digit is insufficient, add 0)	0.0	0.0
12	Vardir	Magnetic declination direction, E (east) or W (west)	M	M
13	Mode ind	Mode indication (only NMEA0183 version 3.00 output, A=autonomous) Positioning, D=difference, E=estimation, N=Invalid data)	a	A
14	*xx	Checksum	*hh	*57
15	[CR][LF]	Sentence terminator		[CR][LF]

3、 GPNTR (distance information from reference station)

Example data:

\$GPNTR,024404.00,1,17253.242,+5210.449,-16447.587,-49.685,0004*40

Data parsing:

NO.	Name	Describe	Symbol	Give an example
1	\$GPNTR	Headers		\$GPNTR
2	utc	UTC time	hhmmss.ss	024404.00
3	pos status	Solution state 0: Invalid solution; 1: Single point positioning solution; 2: Pseudorange difference; 4: Fixed solution; 5: Floating solution;	I	1
4	distance	Diagonal distance from the reference station (meters)	ddd.d	17253.242
5	distance in north	Horizontal distance in X direction: +Indicate in the north direction of the base station -Indicate in the south direction of the base station	ddd.d	+5210.449
6	distance in east	Y-direction horizontal distance: +Indicate that the base station is facing east -Indicate that the base station is facing west	ddd.d	-16447.587
7	Distance in Vertical dimension	Horizontal distance in H direction: +Indicate above the base station -Indicate below the base station	ddd.d	49.685
8	stn ID	Base station number	xxxx	0004
9	*xx	Checksum	*hh	
10	[CR][LF]	End		[CR][LF]

4. GPVTG (Ground Velocity Information)

GPS with BD2

\$GNVTG,46.954,T,46.954,M,0.436,N,0.807,K,A*33

Single BD2

\$BDVTG,150.455,T,150.455,M,0.233,N,0.432,K,A*35

Example data:

\$GPVTG,213.710,T,213.710,M,0.304,N,0.563,K,A*24

Data parsing:

NO.	Name	Describe	Symbol	Give an example
1	\$GPVTG	Headers		\$GPVTG
2	track true	Motion angle	000-359, (If the leading digit is insufficient, add 0)	213.710
3	T	True North Reference Frame	T	T
4	track mag	Motion angle	000-359, (If the leading digit is insufficient, add 0)	213.710
5	M	Magnetic north reference frame	M	M
6	speed Kn	Horizontal movement speed	0.00 (If the leading digit is insufficient, add 0)	0.304
7	N	Knots	N	N
8	speed Km	Horizontal movement speed	0.00 (If the leading digit is insufficient, add 0)	0.563
9	K	Kilometers per hour, km/h	K	K
10	mode ind	position	a	A
11	*xx	Checksum	*hh	*24
12	[CR][LF]	End		[CR][LF]

5、GPGSV statement (visible satellite information)

GPS+BD2+GLONASS

```
$GPGSV,2,1,06,29,32,090,44,26,34,124,44,14,59,116,45,30,25,042,42*71
$GPGSV,3,1,09,01,34,042,43,09,14,216,43,32,33,060,42,04,27,248,42*73
$GPGSV,3,2,09,17,47,323,44,08,16,207,43,20,56,094,48,11,17,061,38*71
$GPGSV,3,3,09,28,81,228,46,,,,,,,,,,,,,*49
$BDGSV,2,1,08,141,47,148,48,142,32,238,43,143,52,201,48,146,53,179,48*65
$BDGSV,2,2,08,147,05,192,40,148,67,026,46,149,26,196,44,150,13,219,39*63
$GLGSV,3,1,09,47,07,193,46,43,46,101,50,59,28,309,45,49,28,305,43*68
$GLGSV,3,2,09,48,35,239,45,42,21,040,44,57,24,063,39,44,24,161,47*67
$GLGSV,3,3,09,58,46,012,45,,,,,,,,,,,,,*51
```

Example data:

```
$GPGSV,<1>,<2>,<3>,<4>,<5>,<6>,<7>,...<4>,<5>,<6>,<7>*hh<CR><LF>
```

Note: Information for<4>,<5>,<6>, and<7>will be displayed in a loop for each satellite, and each GSV statement can display information for up to 4 satellites. Other satellite information will be output in the NMEA0183 statement of the next sequence.

```
$GPGSV,2,1,06,29,32,090,44,26,34,124,44,14,59,116,45,30,25,042,42*71
```

Data parsing:

NO.	Name	Describe	Symbol	Give an example
1	\$GPGSV	Headers		\$GPGSV
2	# msgs	The total number of GSV statements	X	2
3	Msg #	GSV number	X	1
4	# sats	The total number of satellites	XX	6
5	prn	Satellite PRN number GPS = 1 to 32 SBAS = 33 to 64 (add 87 for PRN#s) GLO = 65 to 96 BD2 = 141~177	XX	29
6	elev	Satellite elevation angle	XX	32
7	azimuth	Satellite azimuth	XXX	090
8	SNR	Signal to noise ratio (00~99dB)	XX	44
9	Each satellite displays in a loop		
10	*xx	Checksum	*hh	
11	[CR][LF]	End		[CR][LF]

7、GPTRA (azimuth information) requires dual antennas**Example data:**

```
$GPTRA,063027.30,101.78,071.19,-00.00,4,10,0.00,0004*51
```

Data parsing:

```
$GPTRA,hhmmss.ss,hhh.hh,ppp.pp,rrr.rr,q,n,dd.dd,xxxx*CC<CR><LF>
```

NO.	Name	Describe	Symbol	Give an example
1	\$GPTRA	Headers		\$GPTRA
2	utc	UTC time	hhmmss.ss	104252.00
3	heading	Direction angle, 0~360 degrees	hhh.hh	044.56
4	pitch	Pitch angle: -90~90 degrees	ppp.pp	-09.74
5	roll	Roll angle: -90~90 degrees	rrr.rr	0
6	QF	Solution state 0: Invalid solution; 1: Single point positioning solution; 2: Pseudorange difference; 4: Fixed solution; 5: Floating solution;	q	4
7	sat No.	number of satellites	n	15
8	age	Differential Delay	dd.dd	
9	stn ID	Base station number	xxxx	4
10	*xx	Checksum	*hh	
11	[CR][LF]	End		[CR][LF]

8、Heading requires dual antennas for azimuth information

Data example:

```
#HEADINGA,COM1,0,60.0,FINESTEERING,1709,270809.100,00000000,0000,1114;S
```

```
OL_COMPUTED,NARROW_INT,1.396890879,200.623992920,-6.505328655,0.0,0.01 58,0.0169,"0004",12,12,12,12,0,0,0,0*9fe42a98
```

Data parsing:

NO.	Field type	Descriptives	Data examples
1	Heading header	Data header	#HEADINGA... ..
2	sol stat	Solution status (see Table 19 for details)	SOL_COMPUTED
3	pos type	Positioning type (see Table 20 for details)	NARROW_INT
4	Length	Baseline length (meters)	1.396890879
5	heading	Azimuth angle (0 ° to 360 °)	200.623992920
6	pitch	Tilt angle (0 ° to 90 °)	-6.505328655
7	reserved	reserve	0.0
8	hdg std dev	Azimuth standard deviation (unit: °)	0.0158
9	ptch std dev	Standard deviation of inclination angle (unit: °)	0.0169
10	stn id	Reference value ID	"0004"
11	#SVs	Number of tracked satellites	12
12	#solnSVs	Number of satellites involved in RTK calculation	12
13	#obs	Number of satellites above the cut-off elevation angle	12
14	#multi	Number of satellites tracked to L2 above the cut-off elevation angle	12
17	Reserved	reserve	0
18	Ext sol sta	Extended solution state	0
19	Reserved	reserve	0
20	Sig mask	Signal involved in solving	0
21	CRC	32-bit CRC code	*9fe42a98

Table A Explanation of Solution Status:

Solution state	Describe
SOL_COMPUTED	Complete solution
INSUFFICIENT_OBS	Insufficient observation quantity
COLD_START	Cold start, not fully solved yet

Table B Description of Positioning Status:

Positioning status	Describe
NONE	Unsolved
FIXEDPOS	Fixed coordinates have been set
SINGLE	Single point positioning solution
PSRDIFF	Pseudo range differential positioning solution
NARROW_FLOAT	Float solution
WIDE_INT	Broadband fixed solution
NARROW_INT	Narrowband fixed solution
SUPER WIDE-LANE	Ultra wideband solution

9、 Bestposa(Position coordinate information)

Data example:

```
#BESTPOSA,COM1,0,60.0,FINESTEERING,1709,270776.300,00000000,0000,1114;SO L_
COMPUTED,NARROW_INT,31.92829656994,118.86502034494,7.7675,,WGS84,0.
```

```
0052,0.0052,0.0094,"0004",0.000,6223.000,12,11,12,12,0,0,0,0*292eba23
```

Data parsing:

NO.	Field type	Descriptives	Data examples
1	bestpos header	Data header	#BESTPOSA.....
2	sol stat	Solution status (see Table 19 for details)	SOL_COMPUTED
3	pos type	Positioning type (see Table 20 for details)	NARROW_INT
4	Lat	latitude	31.92829656994
5	Lon	longitude	118.86502034494
6	hgt	High altitude	7.7675
7	undulation	Difference in geoid	empty
8	Datum id#	Coordinate system	WGS84
9	Lat σ	Latitude standard deviation	0.0052
10	Lon σ	Longitude standard deviation	0.0052
11	hgt σ	Elevation standard deviation	0.0094
12	stn id	Reference value ID	"0004"
13	Diff_age	Differential Age (in seconds)	0.000
14	sol_age	Solution time (in seconds)	6223.000
15	#SVs	Number of tracked satellites	12
16	#solnSVs	Number of satellites involved in RTK calculation	11
17	#ggL1	Number of satellites involved in PVT calculation for L1	12
18	#ggL1L2	Number of satellites involved in PVT calculation for L1 and L2	12
19	Reserved	reserve	0
20	Ext sol sta	Extended solution state	0
21	Reserved	reserve	0
22	Sig mask	Signal involved in solving	0
23	CRC	32-bit CRC code	*292eba23

8 Typical Applications

8.1 Application of high-precision positioning for medium and short distances

In high-precision positioning applications for medium to short distances (<3km), the module can be combined with a data transmission module to form a complete high-precision positioning system with only a small amount of external circuits. It is suitable for applications with a large number of mobile stations in a small range, and the module is fully compatible with other automatic flight control systems such as Pixhawk and APM. The schematic diagram is as follows:

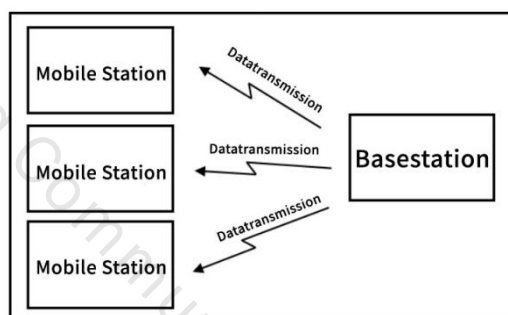

The reference station is stationary and fixed, and differential data is broadcasted to all mobile stations through a data transmission module. The circuit diagrams of the mobile station and the reference station are as follows:

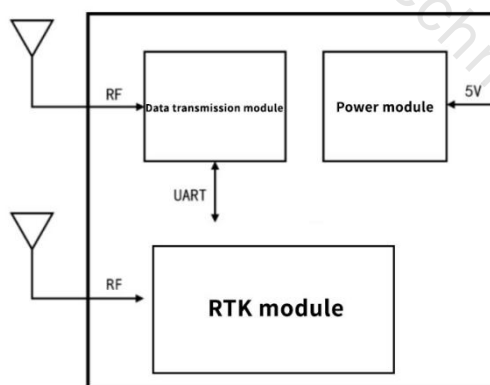

3) If the antenna coordinates have been accurately determined through other surveying methods, please use the # set position command to input the antenna coordinates into the reference station module in latitude, longitude, and altitude format;

4) If the antenna coordinates are unknown, please wait patiently for about 5 minutes. The module will calculate the antenna position as accurately as possible. After th

When the calculation is completed, the differential data port will begin to output data. At this point, the base station has already recorded the coordinates and broadcasted them wirelessly to ensure that the base station does not lose power, as the coordinates will be recalculated after a power outage and the repeatability of the mobile station measurement points cannot be guaranteed;

5) Install the mobile station antenna on the mobile carrier, confirm receipt of differential data, and wait for about 120 seconds to obtain high-precision positioning results.

8.2 Application of Medium to Long Range High Precision Positioning

In the application of high-precision positioning over medium to long distances (<10km), common data transmission modules are difficult to provide reliable differential data connections and suffer from serious packet loss problems. For this purpose, the company provides a solution based on 4G network (as shown in the figure below). The benchmark station sends differential data to the server through a wired network and is cached by the server. Mobile stations access servers through 4G networks to obtain differential data. This solution can greatly expand the coverage area of base stations, and mobile stations equipped with 4G network cards can simultaneously transmit positioning results back to designated servers.

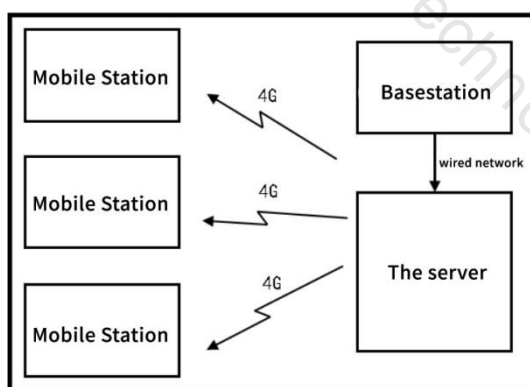

The circuit diagram of the mobile station is as follows:

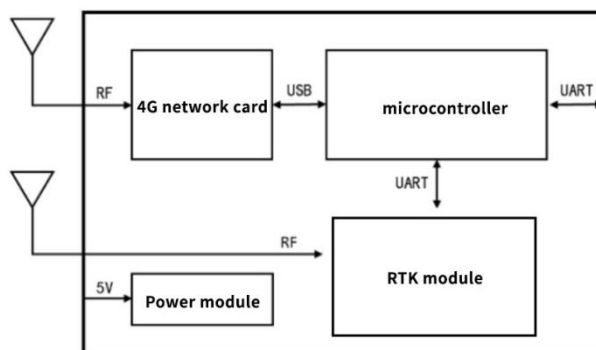

In practical applications, the number of mobile stations that a server can access simultaneously is limited only by server performance and is more suitable for a large number of users. Requirements between the server and the base station: the server can be directly accessed from the public network (with a public IP address), and a network connection can be established between the base station and the server (either through the public network or local area network).

8.3 High precision positioning application without reference station

In high-precision positioning applications without reference stations, the module needs to cooperate with the 4G communication module to obtain differential data. We provide Qianxun with differential data sources nationwide, and users can obtain high-precision positioning results without deploying base stations. The circuit diagram is as follows:

