

# Dalang

## AK973T





# Dalang Communication Technology Co., Ltd Product Specification

Product Name:	GNSS receiver
Product Model:	AK973T
Version Number:	V 1.0
Revision Date:	2024.12.16

# Confidentiality Statement

This document and the information contained within are the property of **"Dalang Communication Technology Co., Ltd"**, and are for use only by authorized individuals for specific purposes. This document contains confidential information. Without explicit written permission from **"Dalang Communication Technology Co., Ltd"**, no person or group may copy, distribute, disseminate, display, or disclose this document or any part of it to a third party in any form. Recipients must strictly adhere to confidentiality obligations, protect the information in the document from being disclosed or misused, and ensure that all relevant personnel follow the same confidentiality rules. Individuals or organizations violating this statement will face legal prosecution and/or contractual penalties.

Thank you for your support and cooperation in protecting the confidential information of **"Dalang Communication Technology Co., Ltd"**.

# Contents

1 Product Application Scenarios .....	1
Figure 1 Product Application Scenarios .....	1
2 Features .....	2
3 Structural Characteristic .....	3
Figure 2 Dimensional Drawing (in millimeters) .....	3
Table 1 PIN Function .....	3
4 Specifications .....	4
Table 2 Product Specifications .....	4
5 Product Photos .....	6
Figure 4 Product Images .....	6
6 Typical Applications .....	7
6.1 Application of high-precision positioning for medium and short distances .....	7
6.2 Application of Medium to Long Range High Precision Positioning .....	8
6.3 High precision positioning application without reference station .....	9

# 1 Product Application Scenarios

The AK973T module employs a comprehensive system-wide RTK engine to deliver real-time centimeter-level differential positioning accuracy, making it suitable for use in drones, automotive applications, and surveying. The module supports both "Rover" and "Base Station" modes, utilizing carrier phase difference technology to precisely eliminate various errors and achieve high-accuracy positioning. In Base Station mode, it outputs data streams conforming to the RTCM2.x/3.x standards, compatible with most commercial rovers, and supports network RTK reference designs. In Rover mode, it is compatible with RTCM2.x/3.x data formats, allowing integration with various base stations or the national Bei Dou Ground-Based Augmentation System. This module offers static positioning accuracy down to 1cm and dynamic positioning accuracy down to 2cm, with an output rate of 1~10Hz, balancing high performance with cost efficiency. See Figure 1 for details.



Figure 1 Product Application Scenarios

## 2 Features

In this chapter, we will delve into and comprehensively elaborate on the functionalities and operating principles of the AK973T, detailing how it plays a pivotal role in various applications as follows:

1. **High-frequency performance stability:** Designed based on the UM960 series, the module maintains stable, high-precision positioning results even in harsh environments, with optimized signal reception capability and enhanced adaptability to temperature and humidity changes.
2. **2. RTK:** Supports multi frequency on-chip RTK positioning and calculation for the entire system, RTK Engine and Starry Sky RTK Technology
3. **High data output:** Supports up to 20Hz data output, meeting the positioning needs of drones in high-speed movement environments, ensuring continuous and stable trajectory tracking.
4. **Interference resistance:** Effectively resists interference from other electronic devices, ensuring clear and accurate positioning signals through reinforced electromagnetic compatibility design, which ensures the stability and accuracy of positioning data.
5. **Compatibility:** Fully compatible with other automatic flight control systems such as Pixhawk and APM, offering good compatibility and supporting seamless integration with various flight platforms.
6. **Low noise:** Employs industrial-grade low noise RF circuitry with strong multipath suppression to enhance signal reception quality.
7. **Accurate heading:** equipped with IST8310 geomagnetic sensor, low power consumption and small size, three-axis high-precision direction finding, strong anti-interference ability

### 3 Structural Characteristic

In this section, we will conduct an in-depth analysis of the product's design details, presenting its aesthetic features and precise interface specifications through detailed structural diagrams. This perspective aims to provide a comprehensive framework, thereby enhancing the understanding and perception of the product's architecture. Refer to Figure 2, Figure 3, Table 1.

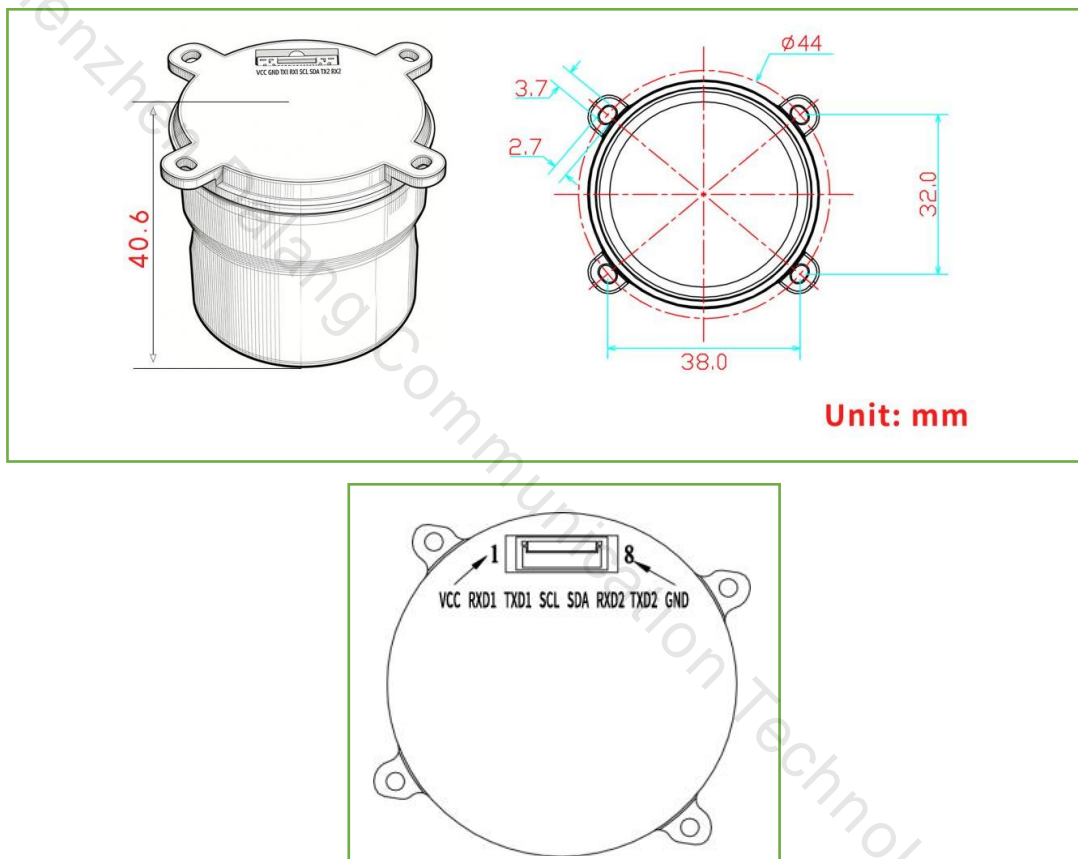

Figure 2 Dimensional Drawing (in millimeters)

Table 1 PIN Function

NO.	Signal Name	Signal Description
1	VCC	Main power input,+ 5V
2	RXD1	Receive data port 1, 3.3VTTL
3	TXD1	Send data port 1, 3.3VTTL
4	SCL	I <sup>2</sup> C Serial Clock (IST8310)
5	SDA	I <sup>2</sup> C Serial Data (IST8310)
6	RXD2	Receive data port 2, 3.3VTTL
7	TXD2	Send data port 2, 3.3VTTL
8	GND	Grounding

## 4 Specifications

In this section, we will provide a detailed list and explanation of the product's chip features, sensitivity, accuracy, operating principles, and other technical details, as detailed in Table 2.

Table 2 Product Specifications

<b>Chip characteristics</b>	chip	UM960			
	working frequency	BDS: B1I、B2I、B3I、B1C、B2a GPS: L1C/A、L2P(W)、L2C、L5 GLONASS: L1C/A、L2C/A Galileo: E1、E5b、E5a QZSS: L1、L2、L5			
	Receiving channel	1408 channel Nebula IVTM			
	Single point positioning (RMS)	Plane: 1.5 meters			
		Elevation: 2.5 meters			
	DGPS (RMS)	Plane: 0.4 meters			
		Elevation: 0.8 meters			
	RTK (RMS)	Flat: 0.8 cm+1ppm			
		Elevation: 1.5 cm+1ppm			
	Observation accuracy (RMS)	BDS	GPS	GLONASS	Galileo
	B1I/L1 C/A/G1/E1 Pseudorange	10cm	10cm	10cm	10cm
	B1I/L1 C/A/G1/E1 carrier phase	1mm	1mm	1mm	1mm
	B2I/L2P (Y)/L2C/G2/E5b pseudorange	10cm	10cm	10cm	10cm
	B2I/L2P (Y)/L2C/G2/E5b carrier phase	1mm	1mm	1mm	1mm
Time accuracy (RMS)	20 ns				
Speed accuracy (RMS)	0.03 m/s				

	Data update rate	20 Hz positioning
	cold boot	< 30s
	Initialization time	<5s (typical value)
<b>Output data</b>	Baud rate	115200bps (default) [Optional: 4800-921600]
	Output interface	TTL
	Output Protocol	NMEA 0183, Unicore*
	update frequency	Default 1Hz (0.25Hz-20Hz)
	Carrier phase output	Support, output RAWX statement
	FLASH	built-in
<b>Working conditions</b>	height	<50,000m
	speed	<500m/s
	Gravitational acceleration	<4g
<b>Electrical specifications</b>	working voltage	5V DC
	power waste	800mW
<b>Physical parameters</b>	size	Φ 44*40.6mm
	weight	21g
	Connector	GH1.25mm 8pin
<b>Environment</b>	working temperature	-40℃-85℃
	Storage temperature	-55℃+95℃
<b>Compass</b>	COMPASS	IST8310(Isentek)

## 5 Product Photos

In this chapter, we will showcase real-life images of the product, as shown in Figure 4. These images provide a detailed view of our product from various angles and perspectives. We believe that through authentic representation, we can better convey the value and concept of the product, thereby enhancing your trust and satisfaction.

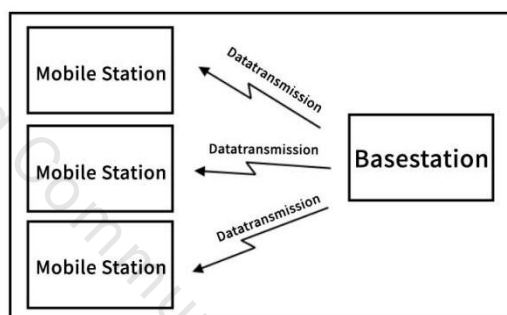

Figure 4 Product Images

## 6 Typical Applications

### 6.1 Application of high-precision positioning for medium and short distances

In high-precision positioning applications for medium to short distances (<3km), the module can be combined with a data transmission module to form a complete high-precision positioning system with only a small amount of external circuits. It is suitable for applications with a large number of mobile stations in a small range, and the module is fully compatible with other automatic flight control systems such as Pixhawk and APM. The schematic diagram is as follows:



The reference station is stationary and fixed, and differential data is broadcasted to all mobile stations through a data transmission module. The circuit diagrams of the mobile station and the reference station are as follows:

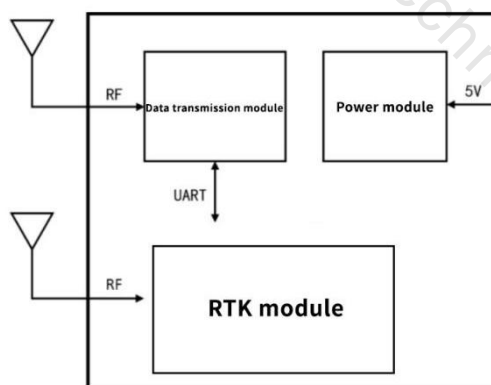

3) If the antenna coordinates have been accurately determined through other surveying methods, please use the # set position command to input the antenna coordinates into the reference station module in latitude, longitude, and altitude format;

4) If the antenna coordinates are unknown, please wait patiently for about 5 minutes. The module will calculate the antenna position as accurately as possible. After the calculation is c

ompleted, the differential data port will begin to output data. At this point, the base station has already recorded the coordinates and broadcasted them wirelessly to ensure that the base station does not lose power, as the coordinates will be recalculated after a power outage and the repeatability of the mobile station measurement points cannot be guaranteed;

5) Install the mobile station antenna on the mobile carrier, confirm receipt of differential data, and wait for about 120 seconds to obtain high-precision positioning results.

## 6.2 Application of Medium to Long Range High Precision Positioning

In the application of high-precision positioning over medium to long distances (<10km), common data transmission modules are difficult to provide reliable differential data connections and suffer from serious packet loss problems. For this purpose, the company provides a solution based on 4G network (as shown in the figure below). The benchmark station sends differential data to the server through a wired network and is cached by the server. Mobile stations access servers through 4G networks to obtain differential data. This solution can greatly expand the coverage area of base stations, and mobile stations equipped with 4G network cards can simultaneously transmit positioning results back to designated servers.

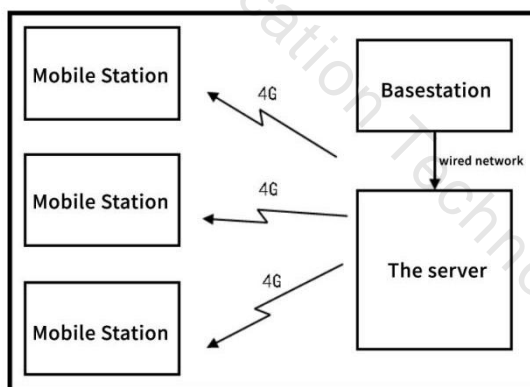

The circuit diagram of the mobile station is as follows:

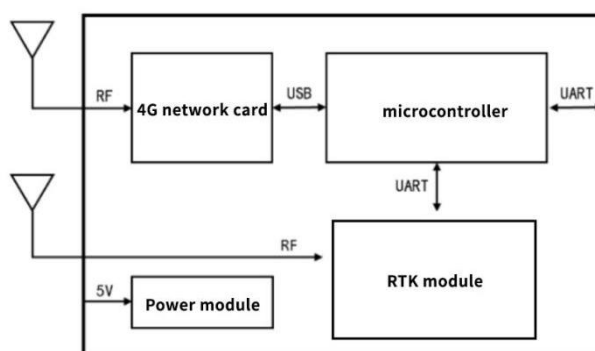

In practical applications, the number of mobile stations that a server can access simultaneously is limited only by server performance and is more suitable for a large number of users. Requirements between the server and the base station: the server can be directly accessed from the public network (with a public IP address), and a network connection can be established between the base station and the server (either through the public network or local area network).

### 6.3 High precision positioning application without reference station

In high-precision positioning applications without reference stations, the module needs to cooperate with the 4G communication module to obtain differential data. We provide Qianxun with differential data sources nationwide, and users can obtain high-precision positioning results without deploying base stations. The circuit diagram is as follows:

