

Dalang

AK714





Dalang Communication Technology Co., Ltd Product Specification

Product Name:	GNSS Receiver
Product Model:	AK714
Version Number:	V 1.0
Revision Date:	2024.10.28

Confidentiality Statement

This document and the information contained within are the property of **"Dalang Communication Technology Co., Ltd"**, and are for use only by authorized individuals for specific purposes. This document contains confidential information. Without explicit written permission from **"Dalang Communication Technology Co., Ltd"**, no person or group may copy, distribute, disseminate, display, or disclose this document or any part of it to a third party in any form. Recipients must strictly adhere to confidentiality obligations, protect the information in the document from being disclosed or misused, and ensure that all relevant personnel follow the same confidentiality rules. Individuals or organizations violating this statement will face legal prosecution and/or contractual penalties.

Thank you for your support and cooperation in protecting the confidential information of **"Dalang Communication Technology Co., Ltd"**.

Contents

1 Product Application Scenarios	1
Figure 1 Product Application Scenarios	1
2 Features	2
3 Structural Characteristic	3
Figure 2 Dimensional Drawing (in millimeters)	3
Table 1 PIN Function	3
4 Specifications	4
Table 2 Product Specifications	4
5 Product Photos	6
Figure 4 Product Images	6
6 Typical Applications	7
6.1 Application of high-precision positioning for medium and short distances	7
6.2 Application of Medium to Long Range High Precision Positioning	8
6.3 High precision positioning application without reference station	9

1 Product Application Scenarios

The AK714 Beidou/GPS/Galileo/GLONASS four-star dual frequency RTK integrated module (referred to as the module) is an ultra-low cost, low-power, high-performance real-time dynamic differential positioning module. The module's highly reliable carrier phase differential technology can provide real-time centimeter level positioning accuracy for unmanned aerial vehicles, automobiles, and surveying users, as shown in Figure 1



Figure 1 Product Application Scenarios

2 Features

In this chapter, we will delve into and comprehensively elaborate on the functionalities and operating principles of the AK714, detailing how it plays a pivotal role in various applications as follows:

1. **Stable high-frequency performance:** Based on the design of the Beiyun M20 series products, the module can achieve stable and high-precision positioning results even in harsh environments.
2. **Fast:** Supports Beidou/GPS/Galileo/Glonass four mode joint RTK calculation, with fast and reliable initialization capabilities.
3. **High data output:** Supports up to 10Hz data output, meeting the application needs of unmanned aerial vehicles in dynamic situations.
4. **Anti interference:** It can effectively resist interference from other electronic devices, ensuring clear and accurate positioning signals.
5. **Compatibility:** Fully compatible with other automatic flight control systems such as Pixhawk and APM, with good compatibility.
6. **Low noise reduction:** Using industrial grade low-noise RF circuits, it has strong resistance to multipath suppression.

3 Structural Characteristic

In this section, we will conduct an in-depth analysis of the product's design details, presenting its aesthetic features and precise interface specifications through detailed structural diagrams. This perspective aims to provide a comprehensive framework, thereby enhancing the understanding and perception of the product's architecture. Refer to Figure 2, Figure 3, Table 1.

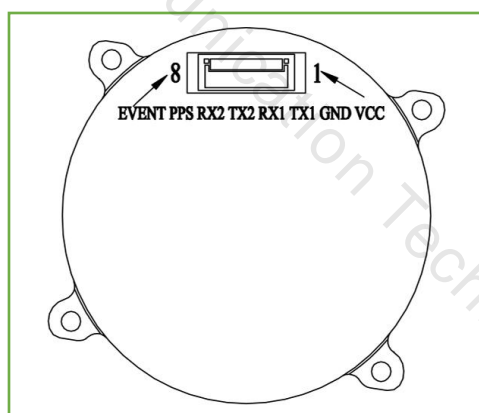
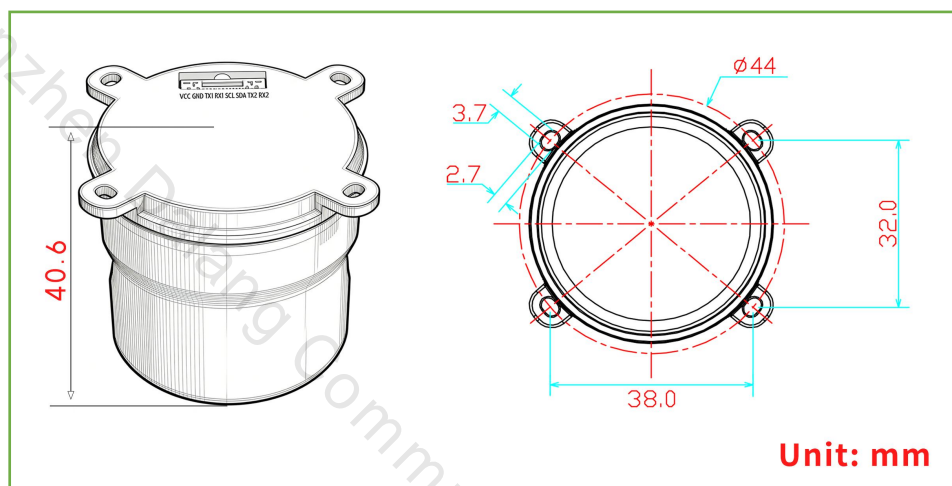

Figure 2 Dimensional Drawing (in millimeters)

Table 1 PIN Function

Pin Number	Signal Name	Signal Description
1	VCC	Main power input, +3.3V to 5V
2	GND	Module ground
3	TX1	UART1 output, 3.3V TTL
4	RX1	UART1 input, 3.3V TTL
5	TX2	UART2 output, 3.3V TTL
6	RX2	UART2 input, 3.3V TTL
7	PPS	Pulse Per Second output for time synchronization
8	EVENT	Module external terminal output (default off)

4 Specifications

In this section, we will provide a detailed list and explanation of the product's chip features, sensitivity, accuracy, operating principles, and other technical details, as detailed in Table 2.

Table 2 Product Specifications

Chip characteristics	working frequency	BDS: B1I、 B2I、 B3I、 B1C、 B2a、 B2b GPS: L1 C/A、 L1C、 L2、 L5 GLO: G1、 G2 GAL: E1、 E5a、 E5b、 E6 QZSS: L1 C/A、 L1C、 L2、 L5、 L6 (CLAS) NavIC: L5 SBAS*: L1 C/A			
	chip	Beiyun M20			
	Receiving channel	1507 channel			
Time To First Fix	cold boot	≤30s			
	Hot start	≤5s			
	Re capture	≤1s			
	RTK initialization	≤ 5 s			
Accuracy	Horizontal positioning accuracy	Single point: 1.5mCEP			
		RTK: 1.0 cm + 1 ppmCEP			
	Elevation positioning accuracy	Single point: 2.5mCEP			
		RTK: 1.5 cm + 1 ppmCEP			
	Observation accuracy (RMS)	BDS	GPS	GLO	GAL
	B1I/B1C/L1C/L1 CA/E1/G1 pseudorange	10cm	10cm	10cm	10cm
	B1I/B1C/L1C/L1 CA/E1/G1 Carrier Phase	1mm	1mm	1mm	1mm
B2I/B2a/B2b/L5/E5a/E5b pseudorange	10cm	10cm	10cm	10cm	
B2I/B2a/B2b/L5/E5a/E5b Carrier Phase	1mm	1mm	1mm	1mm	

	B3I/L2/G2 pseudorange	10cm	10cm	10cm	10cm
	B3I/L2/G2 Carrier Phase	1mm	1mm	1mm	1mm
	Speed accuracy	0.03m/s			
	Timing accuracy	≤20 ns			
Output data	Baud rate	115200bps (default)			
	Output interface	TTL			
	Output Protocol	NMEA,RTCM3.3, BYNAV			
	update frequency	Default 1Hz (1Hz-10Hz)			
	Carrier phase output	Support, output RAWX statement			
	FLASH	built-in			
Working conditions	speed	<550m/s			
	Gravitational acceleration	<4g			
Electrical specifications	working voltage	3V~5.5V DC			
	power waste	<800mW@3.3V			
Physical parameters	size	Φ44*40*40.6mm			
	weight	21g			
	Connector	GH1.25mm 8pin			
Environment	working temperature	-40°C-85°C			
	Storage temperature	-40°C-85°C			

5 Product Photos

In this chapter, we will showcase real-life images of the product, as shown in Figure 4. These images provide a detailed view of our product from various angles and perspectives. We believe that through authentic representation, we can better convey the value and concept of the product, thereby enhancing your trust and satisfaction.

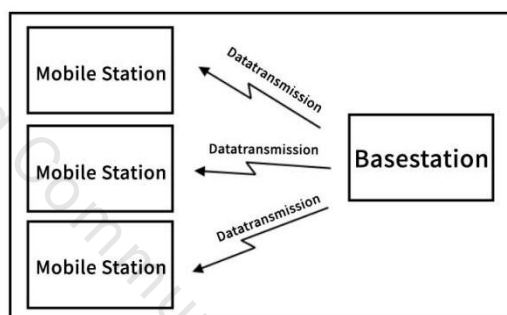

Figure 4 Product Images

6 Typical Applications

6.1 Application of high-precision positioning for medium and short distances

In high-precision positioning applications for medium to short distances (<3km), the module can be combined with a data transmission module to form a complete high-precision positioning system with only a small amount of external circuits. It is suitable for applications with a large number of mobile stations in a small range, and the module is fully compatible with other automatic flight control systems such as Pixhawk and APM. The schematic diagram is as follows:



The reference station is stationary and fixed, and differential data is broadcasted to all mobile stations through a data transmission module. The circuit diagrams of the mobile station and the reference station are as follows:

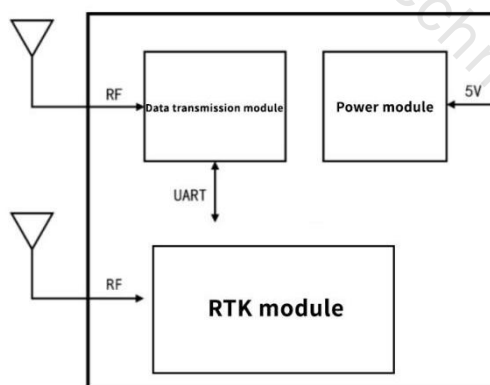

3) If the antenna coordinates have been accurately determined through other surveying methods, please use the # set position command to input the antenna coordinates into the reference station module in latitude, longitude, and altitude format;

4) If the antenna coordinates are unknown, please wait patiently for about 5 minutes. The module will calculate the antenna position as accurately as possible. After the calculation is c

ompleted, the differential data port will begin to output data. At this point, the base station has already recorded the coordinates and broadcasted them wirelessly to ensure that the base station does not lose power, as the coordinates will be recalculated after a power outage and the repeatability of the mobile station measurement points cannot be guaranteed;

5) Install the mobile station antenna on the mobile carrier, confirm receipt of differential data, and wait for about 120 seconds to obtain high-precision positioning results.

6.2 Application of Medium to Long Range High Precision Positioning

In the application of high-precision positioning over medium to long distances (<10km), common data transmission modules are difficult to provide reliable differential data connections and suffer from serious packet loss problems. For this purpose, the company provides a solution based on 4G network (as shown in the figure below). The benchmark station sends differential data to the server through a wired network and is cached by the server. Mobile stations access servers through 4G networks to obtain differential data. This solution can greatly expand the coverage area of base stations, and mobile stations equipped with 4G network cards can simultaneously transmit positioning results back to designated servers.

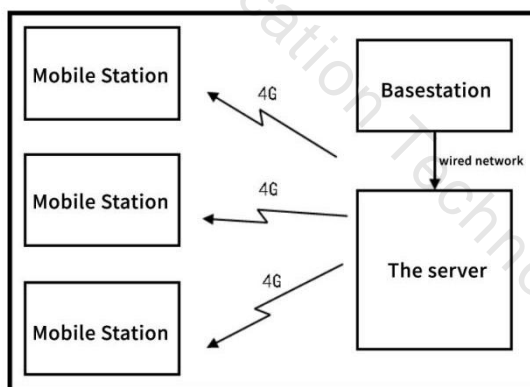

The circuit diagram of the mobile station is as follows:

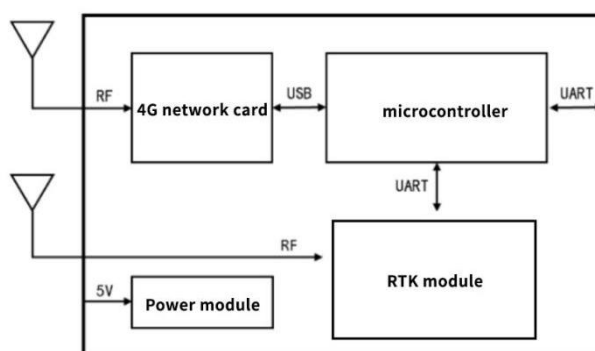

In practical applications, the number of mobile stations that a server can access simultaneously is limited only by server performance and is more suitable for a large number of users. Requirements between the server and the base station: the server can be directly accessed from the public network (with a public IP address), and a network connection can be established between the base station and the server (either through the public network or local area network).

6.3 High precision positioning application without reference station

In high-precision positioning applications without reference stations, the module needs to cooperate with the 4G communication module to obtain differential data. We provide Qianxun with differential data sources nationwide, and users can obtain high-precision positioning results without deploying base stations. The circuit diagram is as follows:

