

# Dalang

**AK712RM**





# Dalang Communication Technology Co., Ltd Product Specification

Product Name:	GNSS Receiver
Product Model:	AK712RM
Version Number:	V 1.0
Revision Date:	2024.11.21

# Confidentiality Statement

This document and the information contained within are the property of **"Dalang Communication Technology Co., Ltd"**, and are for use only by authorized individuals for specific purposes. This document contains confidential information. Without explicit written permission from **"Dalang Communication Technology Co., Ltd"**, no person or group may copy, distribute, disseminate, display, or disclose this document or any part of it to a third party in any form. Recipients must strictly adhere to confidentiality obligations, protect the information in the document from being disclosed or misused, and ensure that all relevant personnel follow the same confidentiality rules. Individuals or organizations violating this statement will face legal prosecution and/or contractual penalties.

Thank you for your support and cooperation in protecting the confidential information of **"Dalang Communication Technology Co., Ltd"**.

# Contents

1 Product Application Scenarios .....	1
Figure 1 Product Application Scenarios .....	1
2 Features .....	2
3 Structural Characteristic .....	3
Figure 2 Dimensional Drawing (in millimeters) .....	3
Table 1 PIN Function .....	3
4 Specifications .....	4
Table 2 Product Specifications .....	4
5 Product Photos .....	6
Figure 4 Product Images .....	6
6 Typical Applications .....	7
6.1 Application of high-precision positioning for medium and short distances .....	7
6.2 Application of Medium to Long Range High Precision Positioning .....	8
6.3 High precision positioning application without reference station .....	9

# 1 Product Application Scenarios

Our company's AK712RM model multi-system dual-frequency RTK module integrates the BeiDou, GPS, Galileo, and GLONASS systems to provide an ultra-cost-effective, low-power, and high-performance real-time centimeter-level dynamic differential positioning solution. Utilizing highly reliable carrier phase differential technology, this module is suitable for drones, automobiles, and surveying applications, ensuring precise positioning. The module supports mobile station and base station modes, effectively eliminating errors in satellite ephemeris, ionospheric disturbances, and other factors through carrier phase differential technology to achieve high-accuracy positioning. In base station mode, it outputs RTCM2.x/3.x standard data, is compatible with most commercial mobile stations, and supports network RTK reference designs. In mobile station mode, it is compatible with RTCM2.x/3.x data formats and can connect to other base stations or the BeiDou ground-based augmentation system. With less than 1 cm static and less than 2 cm dynamic relative positioning accuracy, and a 1~10Hz output rate, this module is suitable for various scenarios and offers an exceptionally high cost-performance ratio. See Figure 1 for details.



Figure 1 Product Application Scenarios

## 2 Features

In this chapter, we will delve into and comprehensively elaborate on the functionalities and operating principles of the AK712RM, detailing how it plays a pivotal role in various applications as follows:

1. **High-frequency performance stability:** Designed based on the UBLOX-F9P series, the module maintains stable, high-precision positioning results even in harsh environments, with optimized signal reception capability and enhanced adaptability to temperature and humidity changes.
2. **Rapid:** Supports Bei Dou/Gps/Galileo/Glonass quad-mode combined RTK calculation, offering fast and reliable initialization capabilities to reduce positioning convergence time.
3. **High data output:** Supports up to 10Hz data output, meeting the positioning needs of drones in high-speed movement environments, ensuring continuous and stable trajectory tracking.
4. **Flexibility:** The module can be flexibly configured as either a base station or a mobile station.
5. **Compatibility:** Fully compatible with other automatic flight control systems such as Pixhawk and APM, offering good compatibility and supporting seamless integration with various flight platforms.
6. **Low Noise Reduction:** Features industrial-grade low noise RF circuits, strong multipath suppression, and improved signal reception quality.
7. **High Precision:** Supports both differential positioning and vector measurement modes, enhancing signal reception capabilities, and simultaneously outputting high-precision positioning and orientation results.
8. **Strong heading:** Added RM3100 geomagnetic sensor, three-axis low-noise anti-interference, accurate heading data output

### 3 Structural Characteristic

In this section, we will conduct an in-depth analysis of the product's design details, presenting its aesthetic features and precise interface specifications through detailed structural diagrams. This perspective aims to provide a comprehensive framework, thereby enhancing the understanding and perception of the product's architecture. Refer to Figure 2, Figure 3, Table 1.

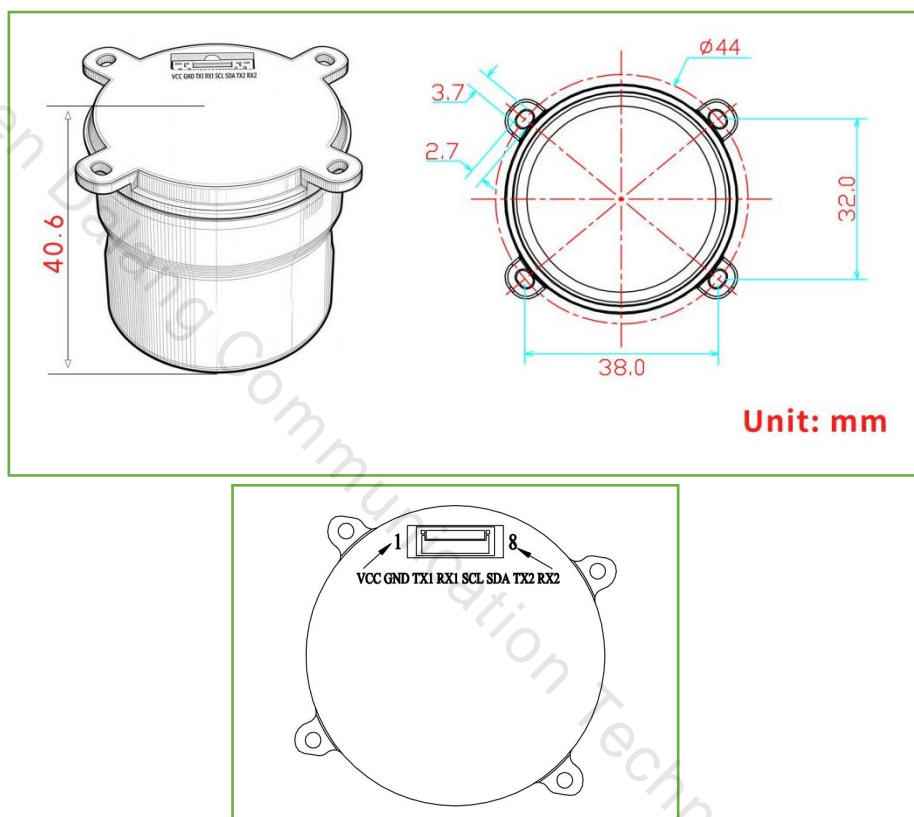

Figure 2 Dimensional Drawing (in millimeters)

Table 1 PIN Function

NO.	Signal Name	Signal Description
1	VCC	Main power input+ 3.3V~5V
2	GND	Module grounding
3	TX1	UART1 output, 3.3V TTL
4	RX1	UART1 input, 3.3VTTL
5	SCL	I <sup>2</sup> C Serial Clock (RM3100)
6	SDA	I <sup>2</sup> C Serial Data (RM3100)
7	TX2	UART1 output, 3.3V TTL
8	RX2	UART1 input, 3.3VTTL

## 4 Specifications

In this section, we will provide a detailed list and explanation of the product's chip features, sensitivity, accuracy, operating principles, and other technical details, as detailed in Table 2.

Table 2 Product Specifications

<b>Chip characteristics</b>	chip	UBLOX-F9P
	working frequency	BDS: B1 B2 GPS: L1 L2 GLONASS: G1 G2 GALILEO: E1 E5b QZSS: L1 L2
	Receiving channel	184 search channel
<b>Sensitivity</b>	track	-167 dBm
	Re capture	-160 dBm
	cold boot	-148 dBm
	Hot start	-157 dBm
<b>First positioning time T TFF</b>	cold boot	26s
	Hot start	2s
	Re capture	2s
<b>Accuracy</b>	RTK horizontal accuracy	0.01 m + 1 ppm CEP
	RTK vertical accuracy	0.01 m + 1 ppm CEP
	Single point horizontal accuracy	1.5m CEP
	Single point vertical accuracy	1.5m CEP
	Speed accuracy	0.05m/s
	1PPS time accuracy	RMS 30ns 99% 60ns
<b>Convergence time</b>	Convergence time	≤10s
<b>Output data</b>	Baud rate	38400bps (default) [Optional: 4800-921600]
	Output interface	TTL
	Output Protocol	NMEA0183, RTCM 3.3, UBX

	update frequency	Default 1Hz (0.25Hz-10Hz)
	Carrier phase output	Support, output RAWX statement
	FLASH	built-in
<b>Working conditions</b>	height	<50,000m
	speed	500m/s
	Gravitational acceleration	≤4g
<b>Electrical specifications</b>	working voltage	3V-5.5V DC
	power waste	<180mW @3.3V
<b>Physical parameters</b>	size	Φ44*40.6mm
	weight	21g
	Connector	GH1.25mm 8pin
<b>Environment</b>	working temperature	-35°C+80°C
	Storage temperature	-40°C+85°C
<b>Compass</b>	compass	RM3100

## 5 Product Photos

In this chapter, we will showcase real-life images of the product, as shown in Figure 4. These images provide a detailed view of our product from various angles and perspectives. We believe that through authentic representation, we can better convey the value and concept of the product, thereby enhancing your trust and satisfaction.

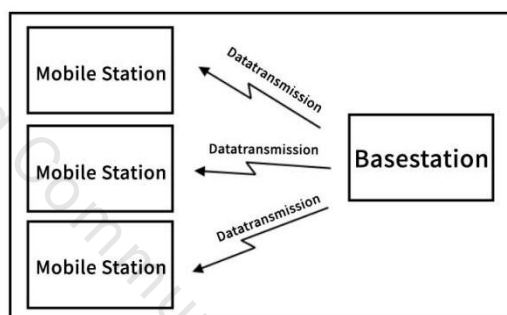

Figure 4 Product Images

## 6 Typical Applications

### 6.1 Application of high-precision positioning for medium and short distances

In high-precision positioning applications for medium to short distances (<3km), the module can be combined with a data transmission module to form a complete high-precision positioning system with only a small amount of external circuits. It is suitable for applications with a large number of mobile stations in a small range, and the module is fully compatible with other automatic flight control systems such as Pixhawk and APM. The schematic diagram is as follows:



The reference station is stationary and fixed, and differential data is broadcasted to all mobile stations through a data transmission module. The circuit diagrams of the mobile station and the reference station are as follows:

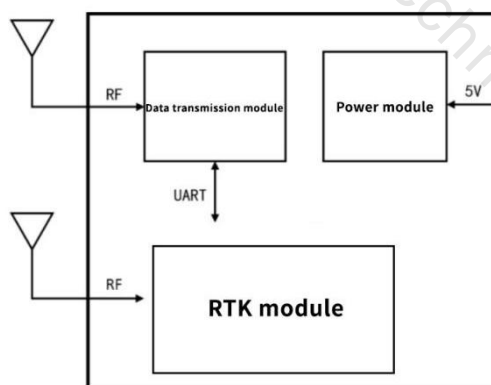

3) If the antenna coordinates have been accurately determined through other surveying methods, please use the # set position command to input the antenna coordinates into the reference station module in latitude, longitude, and altitude format;

4) If the antenna coordinates are unknown, please wait patiently for about 5 minutes. The module will calculate the antenna position as accurately as possible. After the calculation is c

ompleted, the differential data port will begin to output data. At this point, the base station has already recorded the coordinates and broadcasted them wirelessly to ensure that the base station does not lose power, as the coordinates will be recalculated after a power outage and the repeatability of the mobile station measurement points cannot be guaranteed;

5) Install the mobile station antenna on the mobile carrier, confirm receipt of differential data, and wait for about 120 seconds to obtain high-precision positioning results.

## 6.2 Application of Medium to Long Range High Precision Positioning

In the application of high-precision positioning over medium to long distances (<10km), common data transmission modules are difficult to provide reliable differential data connections and suffer from serious packet loss problems. For this purpose, the company provides a solution based on 4G network (as shown in the figure below). The benchmark station sends differential data to the server through a wired network and is cached by the server. Mobile stations access servers through 4G networks to obtain differential data. This solution can greatly expand the coverage area of base stations, and mobile stations equipped with 4G network cards can simultaneously transmit positioning results back to designated servers.

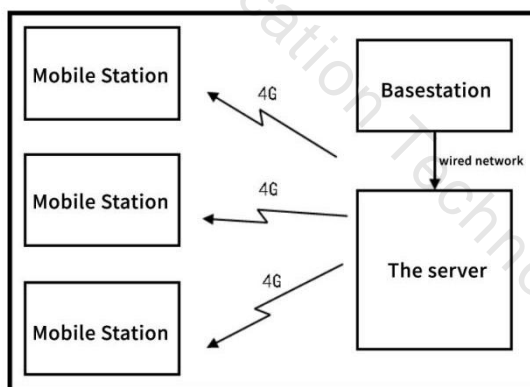

The circuit diagram of the mobile station is as follows:

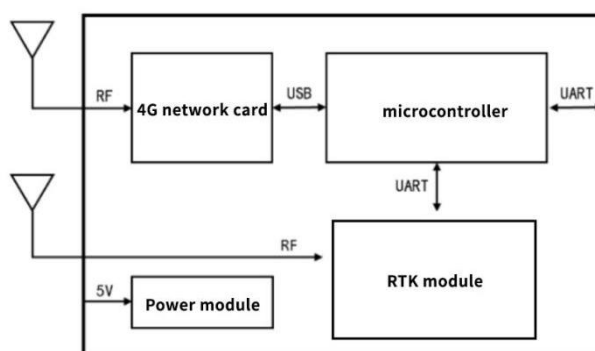

In practical applications, the number of mobile stations that a server can access simultaneously is limited only by server performance and is more suitable for a large number of users. Requirements between the server and the base station: the server can be directly accessed from the public network (with a public IP address), and a network connection can be established between the base station and the server (either through the public network or local area network).

### 6.3 High precision positioning application without reference station

In high-precision positioning applications without reference stations, the module needs to cooperate with the 4G communication module to obtain differential data. We provide Qianxun with differential data sources nationwide, and users can obtain high-precision positioning results without deploying base stations. The circuit diagram is as follows:

