



AK985





Dalang Communication Technology Co., Ltd Product Specification

Product Name:	GNSS Receiver
Product Model:	AK985
Version Number:	V 1.0
Revision Date:	2025.04.22

Confidentiality Statement

This document and the information contained within are the property of **"Dalang Communication Technology Co., Ltd"**, and are for use only by authorized individuals for specific purposes. This document contains confidential information. Without explicit written permission from **"Dalang Communication Technology Co., Ltd"**, no person or group may copy, distribute, disseminate, display, or disclose this document or any part of it to a third party in any form. Recipients must strictly adhere to confidentiality obligations, protect the information in the document from being disclosed or misused, and ensure that all relevant personnel follow the same confidentiality rules. Individuals or organizations violating this statement will face legal prosecution and/or contractual penalties.

Thank you for your support and cooperation in protecting the confidential information of **"Dalang Communication Technology Co., Ltd"**.

Contents

1 Product Application Scenarios	1
Figure 1 Product Application Scenarios	1
2 Features	2
3 Structural Characteristic	3
Figure 1 Product Structure Diagram	3
Table 1 M8 Interface Definition	3
4 Specifications	4
Table 3 Product Specifications	4
5 Product Photos	5
Figure 6 Product Images	5
6 status indicator	6
7 Common configuration instructions	7
8 4G RTK ROVER instructions	8
8.1 Preparation work	8
8.2 Parameter configuration	8
8.3 Change bluetooth name.	9
8.4 firmware upgrade	10
9 Typical applications	11

1 Product Application Scenarios

AK985 is a 4G RTK positioning terminal device (with an external positioning module) that transmits RTK differential base station data to the positioning module through 4G network to achieve RTK accurate positioning. The terminal supports Ntrip communication protocol and supports network base station services such as Qianxun position, CORS station, and self built station. Adopting industry-leading 4G hardware solutions, with built-in 4G antennas, supporting the network standards of most domestic and European operators, and adopting a 5.5-36V wide power input design, it supports outputting 5V power to the positioning module. Refer to Figure 1 for details.



Figure 1 Product Application Scenarios

2 Features

In this chapter, we will delve into and comprehensively elaborate on the functionalities and operating principles of the K985, detailing how it plays a pivotal role in various applications as follows:

- 1. Network module optimization:** Industrial grade 4G network communication module is adopted.
- 2. Network positioning:** Based on 4G network transmission of RTK differential base station data to achieve accurate positioning, supporting Ntrip communication protocol, adapting to network base station services such as Qianxun location, CORS station, and self built station.
- 3. Hardware solution:** Adopting industry-leading 4G hardware solution, built-in 4G antenna, compatible with most domestic and European operator network standards.
- 4. Power supply design:** It has a wide voltage input design of 5.5-36V and can also output 5V power to the positioning module.
- 5. Flexibility:** The positioning module adopts an external module design, with flexible and convenient combination methods to adapt to different customer needs.

3 Structural Characteristic

In this section, we will conduct an in-depth analysis of the product's design details, presenting its aesthetic features and precise interface specifications through detailed structural diagrams. This perspective aims to provide a comprehensive framework, thereby enhancing the understanding and perception of the product's architecture. Refer to Figure1, Table 1。

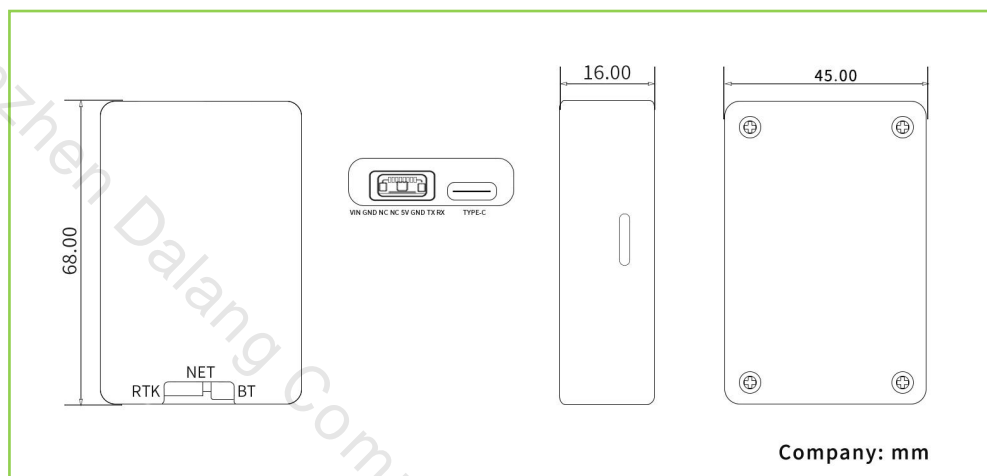

Figure 1 Product Structure Diagram

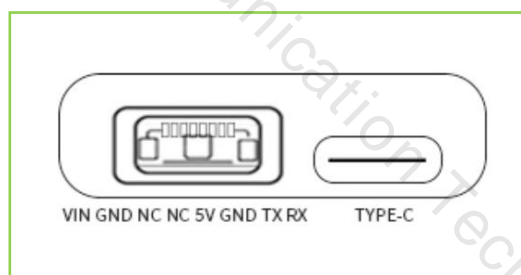

Table 1 M8 Interface Definition

NO.	PIN name	Describe
1	VIN-	DC5.5~36V input
2	GND	grounding
3	NC	empty
4	NC	empty
5	5V_OUT	DC5V output (available for positioning module)
6	GND	grounding
7	TX	Differential transmission (connected to differential serial port RX of positioning module)
8	RX	Differential reception (connected to differential serial port TX of positioning module)
TYPE-C interface		
1	TYPE-C	Terminal configuration USB serial port

4 Specifications

In this section, we will provide a detailed list and explanation of the product's chip features, sensitivity, accuracy, operating principles, and other technical details, as detailed in Table 3.

Table 3 Product Specifications

Specification parameters			
4G module (Network frequency band)	1	LTE FDD	B1/3/5/8
	2	LTE TDD	B34/38/39/40/41(Full frequency band)
	3	GSM/GPRS/EDGE	NA
4G module (Spread speed)	1	LTE FDD (Mbps)	10.3(DL)/5.1(UL)
	2	LTE TDD (Mbps)	9.1(DL)/3.1(UL)
Bluetooth module	1	Bluetooth version	2.0
	2	Working frequency band	2.4G
	3	air rate	2Mbps
	4	Reference distance	10m
Structural characteristics	1	size	68mm*45mm*16mm
	2	weight	30g
	3	connector	SH1.0mm 8PIN / TYPE-C
	4	Housing material	ABS+PC
Electrical and Environmental	1	working voltage	DC5.5~36V
	2	Working current	≤110mA/12V(including external positioning module)
	3	operation temperature	-30°C~+70°C
	4	storage temperature	-40°C~+85°C

5 Product Photos

In this chapter, we will showcase real-life images of the product, as shown in Figure 6. These images provide a detailed view of our product from various angles and perspectives. We believe that through authentic representation, we can better convey the value and concept of the product, thereby enhancing your trust and satisfaction.



Figure 6 Product Images

6 status indicator

NET (green) light	Light	The 4G module is powered on, but PPP dialing is not completed
	flash mob	PPP dial-up completed
	Slow flashing	Registered RTK NTRIP base station
RTK (blue) light	Light	Not positioned
	flash mob	Positioned but not entered RTK fixed solution
	Slow flashing	RTK fixed solution
BT (blue) light	Light	Bluetooth connected
	flash mob	Bluetooth not connected

Note: Slow flashing: on for 400ms, off for 800ms

flash mob: on 200ms, off 200ms

7 Common configuration instructions

NO.	Instruction	Describe	Notes
1	AT+set_ntrip_param,140.207.166.210,25001,,,SZ-DL-8KM-RTCM32#	Set ntrip IP, port, username, password, and loading point	Please separate each item with a comma. If there is no username or password, do not write it, but also separate it with a comma
2	AT+get_ntrip_param#	Query ntrip parameters	
3	AT+get_verno#	Versions Query	
4	AT+set_to_bt,NAMEAK987#	Set Bluetooth name	Note that setting the Bluetooth name must be done when the Bluetooth is not connected. When changing it, disconnect the Bluetooth connection first. The AK987 command shows the Bluetooth name displayed after the change, which can be changed according to your own needs
5	AT+set_uart_gps,1#	Enable MCU serial port forwarding of GPS information	This command will be saved in case of power failure, but if the factory reset command is sent, it will default to no output
6	AT+set_uart_gps,0#	Turn off MCU serial port forwarding GPS information	
7	AT+set_gps_rtk_timer,10#	Set 10 seconds to send GGA information to the ntrip server	10 "is 10 seconds, can be changed to 5 seconds or other, default is 10 seconds

Note: AT commands can be sent from MCU serial port or Bluetooth. When sending commands via Bluetooth on a mobile app, try to edit the text in English as much as possible to avoid text errors

8 4G RTK ROVER instructions

8.1 Preparation work

8.1.1 Connect the AK985 configuration USB cable to the computer USB (Windows 10 and above computer systems will automatically generate serial port numbers, Windows 7 and above computer systems need to install the CH340 serial port driver first) . Open the RTKYupdateTool_1.1CH.exe configuration tool software on the computer

8.2 Parameter configuration

Open the RTKUpdateTool_1 .1CH.exe software and select a good string of slogans, baud rate 115200, click to open the serial port, fill in the IP (or domain name), port, username, password, access point in the corresponding window of the software interface (the IP bar supports entering the domain name, username and password If not, do not fill in), click Settings after all input is completed, and the bottom of the software returns "wait 10s system reset! set_ntrip_param", 000.000.000.000, 25001, SZ-DL-8KM-RTCM32 ok #indicates that the setting is successful (the content of the underlined part is the IP port and other parameters actually set in, and the actual content is consistent with the setting content.

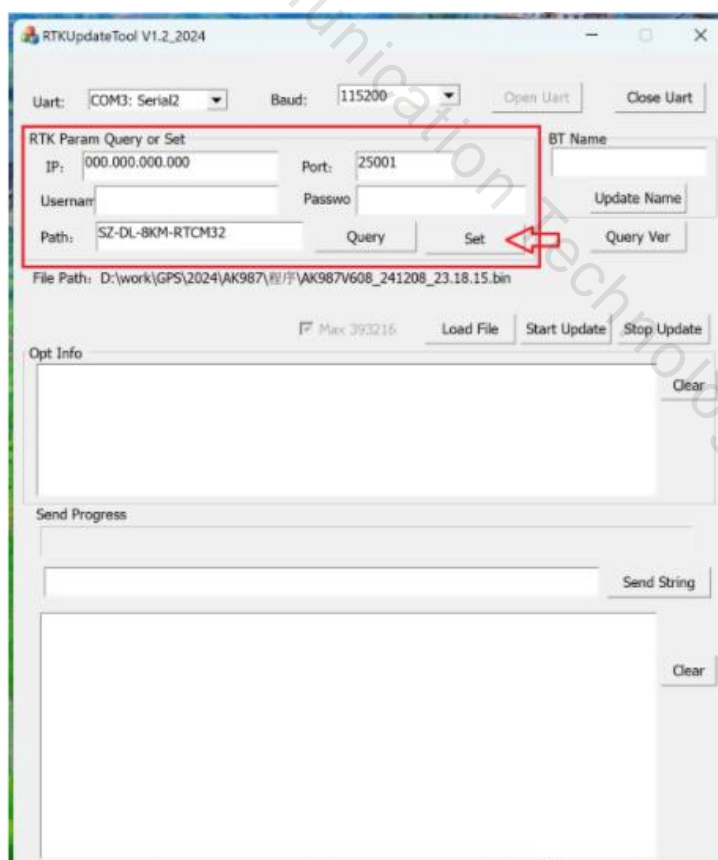

8.3 Change bluetooth name.

AK985 supports customers to modify the Bluetooth name by themselves. Just fill in the Bluetooth name you want to modify in the Bluetooth name window of the RTKUpdateTool_1.1CH.exe tool, and click Modify Name to complete the change. The bottom interface of the software returns set_to_bt, NAMEAK985, ok # (the underlined content is the changed Bluetooth name). It should be noted that the modification of the Bluetooth name must be carried out without a Bluetooth connection, that is, when you see the end point BT indicator flashing, the Bluetooth name must not exceed 16 characters.

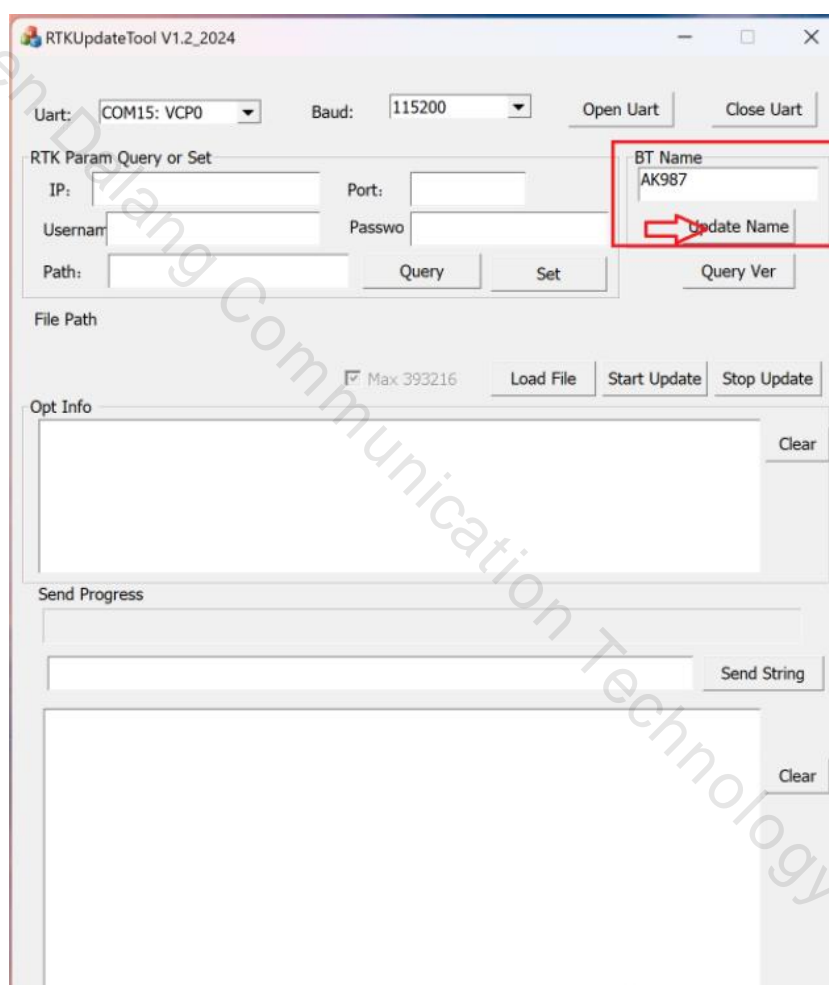

8.4 firmware upgrade

RTKUpdateTool_1 tool software can be AK985 product firmware upgrade, open the software to select a good serial port, baud rate 115200, click to open the serial port, click to load the file to select the firmware, and then click to start the upgrade, waiting for the progress bar to complete, and the sending window shows the upgrade is complete, the current version of the sending window is the version before the upgrade, see the receiving window shows system start that has been upgraded and end point restart, then click the query version button, the receiving window returns to the upgraded version.

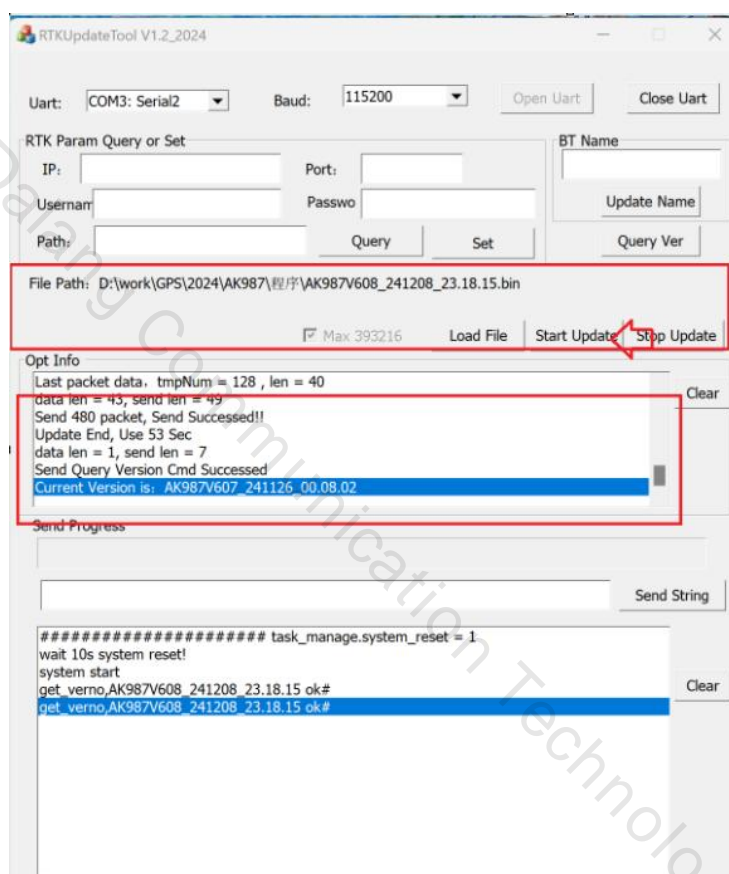

9 Typical applications

9.1 Common data transmission modules are difficult to provide reliable differential data connections, resulting in serious packet loss issues. For this purpose, the company provides a solution based on 4G network (as shown in the figure below). The benchmark station sends differential data to the server through a wired network and is cached by the server. Mobile stations access servers through 4G networks to obtain differential data. This solution can greatly expand the coverage area of base stations, and mobile stations equipped with 4G network cards can simultaneously transmit positioning results back to designated servers.

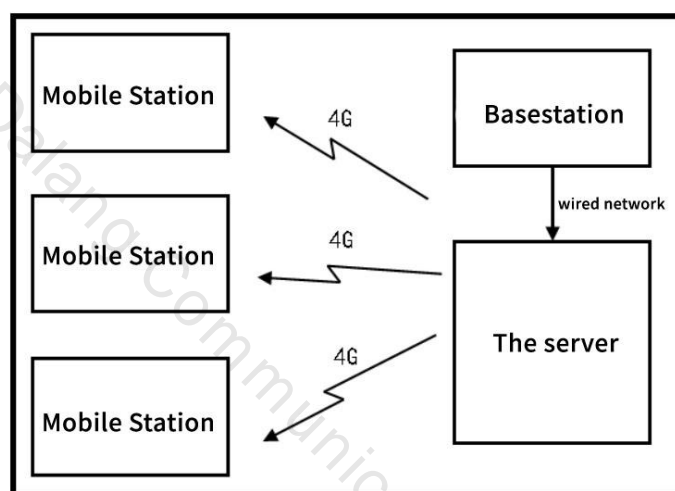

The circuit diagram of the mobile station is as follows:

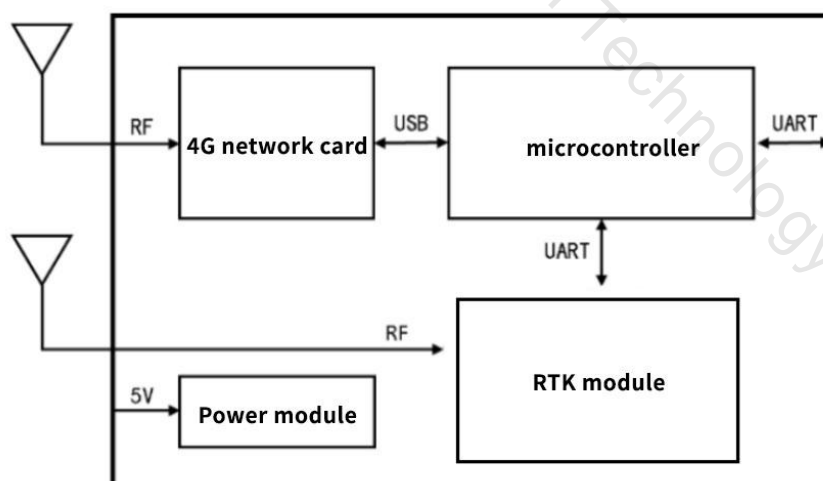

In practical applications, the number of mobile stations that a server can access simultaneously is limited only by server performance and is more suitable for a large number of users. Requirements between the server and the base station: the server can be directly accessed from the public network (with a public IP address), and a network connection can be established between the base station and the server (either through the public network or local area network).

9.2 In high-precision positioning applications without reference stations, the module needs to cooperate with the 4G communication module to obtain differential data. We provide Qianxun with differential data sources nationwide, and users can obtain high-precision positioning results without deploying base stations. The circuit diagram is as follows:

