

# Dalang

## AK978H





# Dalang Communication Technology Co., Ltd Product Specification

Product Name:	GNSS Receiver
Product Model:	AK978H
Version Number:	V 1.0
Revision Date:	2024.05.27

# Confidentiality Statement

This document and the information contained within are the property of **"Dalang Communication Technology Co., Ltd"**, and are for use only by authorized individuals for specific purposes. This document contains confidential information. Without explicit written permission from **"Dalang Communication Technology Co., Ltd"**, no person or group may copy, distribute, disseminate, display, or disclose this document or any part of it to a third party in any form. Recipients must strictly adhere to confidentiality obligations, protect the information in the document from being disclosed or misused, and ensure that all relevant personnel follow the same confidentiality rules. Individuals or organizations violating this statement will face legal prosecution and/or contractual penalties.

Thank you for your support and cooperation in protecting the confidential information of **"Dalang Communication Technology Co., Ltd"**.

# Contents

1 Product Application Scenarios .....	1
Figure 1 Product Application Scenarios .....	1
2 Features .....	2
3 Structural Characteristic .....	3
Figure 2 Interface Definition Diagram .....	3
Table 1 M8 Interface Definition .....	3
Figure 3 Connection line structure diagram .....	4
Figure 4 Complete Solution Connection Diagram .....	4
Table 2 Product Descriptions .....	4
4 Specifications .....	5
Table 3 Product Specifications .....	5
5 Product Photos .....	7
Figure 6 Product Images .....	7
6 Operating .....	8
6.1 Power on Test .....	8
6.2 Radio Configuration .....	8
6.3 GNSS module instruction configuration .....	8
6.3.1 Mobile Station Output .....	9
7 Common configuration instructions for Radio .....	10
8 Typical applications .....	12

# 1 Product Application Scenarios

AK978H is a high-precision positioning and heading GNSS receiver. Its primary and secondary antennas can simultaneously track multiple frequencies of all GNSS systems, and the module can perform chip level RTK positioning and dual antenna heading calculation. The built-in advanced anti-interference unit ensures that the module can provide reliable and accurate positioning data even in complex electromagnetic environments. Compatible with multiple data transmission protocols in the industry: supports SOUTH Transmission protocols such as TRIMATLK, TRANSEOT, TRIMMARK 3, etc; We can support the agreement requirements of other manufacturers in the industry according to customer needs. The K978H has excellent positioning performance and stability, making it an ideal choice for high-precision navigation and positioning applications such as drones, lawn mowers, precision agriculture, and intelligent driving. Refer to Figure 1 for details.



Figure 1 Product Application Scenarios

## 2 Features

In this chapter, we will delve into and comprehensively elaborate on the functionalities and operating principles of the AK978H, detailing how it plays a pivotal role in various applications as follows:

- 1. Support full constellation multi frequency chip level RTK positioning and dual antenna heading solutions.**
- 2. Supports BDS, GPS, GLONASS, Galileo, QZSS, and SBAS.**
- 3. Can be used as a base station or mobile station, as well as for heading.**
- 4. Adaptive recognition of differential input RTCM format.**
- 5. Adopt on-board standard 9-36V wide voltage input.**
- 6. Adopt industrial grade 1W wireless radio module.**

### 3 Structural Characteristic

In this section, we will conduct an in-depth analysis of the product's design details, presenting its aesthetic features and precise interface specifications through detailed structural diagrams. This perspective aims to provide a comprehensive framework, thereby enhancing the understanding and perception of the product's architecture. Refer to Figure 2, Table 1, Figure 3, Table 2, Figure 4, Figure 5.

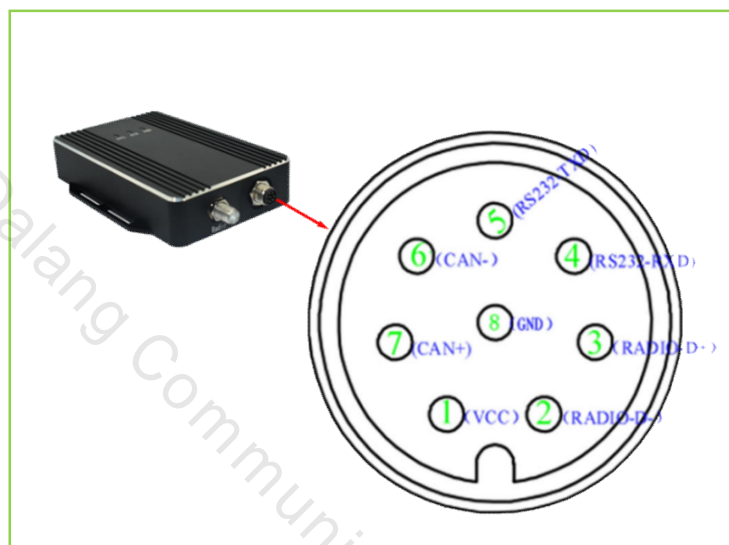

Figure 2 Interface Definition Diagram

Table 1 M8 Interface Definition

M8-8P Male Interface Description		
No.	Interface Name	Function Description
1	VCC	Input voltage 9-36V (typical value 12V), current 3A
2	RADIO-D-	Radio serial port USB D-
3	RADIO-D+	Radio serial port USB D+
4	RS232-RXD	GNSS module RS232 RXD
5	RS232-TXD	GNSS module RS232 TXD
6	CAN-	NC
7	CAN+	NC
8	GND	Mainboard GND
LED Indicator Interaction		
1	PWR	The power indicator light is always red during normal operation, flashing red and green alternately during transmission, and flashing red and blue alternately during reception
2	RTK	Differential positioning indicator, solid blue in FIX state
3	PPS	Positioning indicator, green light flashes, provides an output pulse per second (1PPS) signal with adjustable pulse width and polarity
Antenna Interface Definition		
1	GNSS 1 Antenna	SMA female, primarily receives GNSS antenna signals, antenna power supply 5V
2	GNSS 2 Antenna	SMA female, primarily receives GNSS antenna signals, antenna power supply 5V
3	Radio Antenna	SMA male, primarily receives/transmits 410-470MHz antenna signals

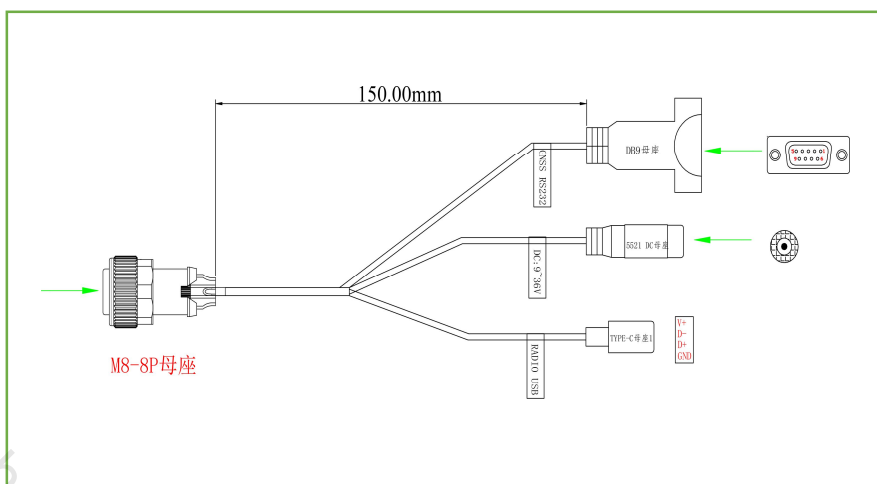

Figure 3 Connection line structure diagram



Figure 4 Complete Solution Connection Diagram

Table 2 Product Descriptions

No.	Product Name	Function Description
1	Connection Cable	8-pin aviation connector to Type-C; DC-DC power; DB9 female connector
2	Receiver	Built-in GNSS module and Radio module
3	Radio Antenna	433±20MHz antenna
4	5-meter Coaxial Cable	TNC to SMA, 50-3 cable
5	5-meter Coaxial Cable	TNC to SMA, 50-3 cable
6	GNSS1Antenna	All-system, all-frequency antenna
7	GNSS2Antenna	All-system, all-frequency antenna

## 4 Specifications

In this section, we will provide a detailed list and explanation of the product's chip features, sensitivity, accuracy, operating principles, and other technical details, as detailed in Table 3.

Table 3 Product Specifications

Specification parameters						
GNSS module	1	Working mode	BDS: B1I、B2I、B3I GPS: L1C/A、L2P (Y)、L2C、L5 GLONASS: L1、L2 Galileo: E1、E5a、E5b QZSS: L1、L2、L5			
	2	Receiving channel	1408 channel			
	3	Single point positioning (RMS)	Plane: 1.5m Elevation: 2.5m			
	4	DGPS(RMS)	Plane: 0.4m+1ppm Elevation: 0.8m+1ppm			
	5	RTK(RMS)	Flat: 0.008m+1ppm Elevation: 0.015m+1ppm			
	6	Directional accuracy (RMS)	0.2 degrees/1m baseline			
	7	Time accuracy (RMS)	20ns			
	8	Speed accuracy (RMS)	0.03m/s			
	9	Observation accuracy (RMS)	BDS	GPS	GLONASS	Galileo
	10	B1I/B1C/L1 C/A/E1/G1 pseudorange	10cm	10cm	10cm	10cm
	11	B1I/B1C/L1 C/A/E1/G1 carrier phase	1mm	1mm	1mm	1mm
	12	B3I/L2P (Y)/L2C/G2 pseudorange	10cm	10cm	10cm	10cm
	13	B3I/L2P (Y)/L2C/G2 carrier phase	1mm	1mm	1mm	1mm
	14	B2I/L5/E5a/E5b pseudorange	10cm	10cm	10cm	10cm
	15	B2I/L5/E5a/E5b carrier phase	1mm	1mm	1mm	1mm
	16	cold boot	<30s			
	17	Initialization time	<5s (typical value)			
Radio module	1	frequency range	410-470MHz			
	2	Channel spacing	25KHz			

	3	Working mode	half-duplex
	4	Frequency stability	$< \pm 1.5 \text{ppm}$
	5	modulation mode	GMSK \ 4FSK
	6	Airborne baud rate	9600bps 19200bps
	7	Protocol type	TRIMATLK/South/TRANSEOT/TRIMMARK3
	8	Serial port baud rate	4800/9600/19200/38400/115200bps
	9	Power (typical value)	High power transmission: 4.0W@3.3V DC Low power (0.5W): 27.0 $\pm$ 1.2dBm@DC 3.3V Machine standby: 0.3W@3.3V DC
	10	Transmitting RF output power (410-470MHz)	High power (1.0W): 30.2 $\pm$ 1.0dBm@DC 3.3V Low power (0.5W): 27.0 $\pm$ 1.2dBm@DC 3.3V
	11	Stability of RF power transmission	$\leq \pm 1 \text{dB}$
	12	Receiver Sensitivity	$> -115 \text{dBm@BER } 10^{-3}, 9600 \text{bps}$
	13	Receive common channel suppression	$> -12 \text{dB}$
<b>Interface</b>	1	Wireless interface	SMA ports
	2	GNSS interface	SMA ports
	3	Data/power interface	8-core LEMO ports
<b>Data format</b>	1	Differential data	RTCM3.X
	2	output format	NMEA-0183, RTCM3.X
	3	Data update rate	1Hz-20Hz(default 1Hz)
<b>power supply</b>	1	Voltage	DC +9V ~ 36V
	2	power waste	$< 3 \text{W}$
	3	indicator light	1power, 1PPS, 1RTK
<b>Physical parameters</b>	1	size	100mm*61.8mm*18.75mm
	2	weight	180g
	3	Shell material	aluminium
<b>Environmental Specifications</b>	1	working temperature	$-30^{\circ}\text{C} \sim +70^{\circ}\text{C}$
	2	Storage temperature	$-55^{\circ}\text{C} \sim +85^{\circ}\text{C}$
	3	humidity	95%condensation
	4	Protection grade	IP66
	5	Seismic resistance	Resist the impact of a 1-meter free fall

## 5 Product Photos

In this chapter, we will showcase real-life images of the product, as shown in Figure 6. These images provide a detailed view of our product from various angles and perspectives. We believe that through authentic representation, we can better convey the value and concept of the product, thereby enhancing your trust and satisfaction.



Figure 6 Product Images

## 6 Operating

### 6.1 Power on Test

a) Connect the serial port cable (DB9 to USB) to the PC, turn on the power (9-36V), confirm that the device is working properly (the power red light PWR is always on, and the PPS green light starts flashing continuously when the antenna is correctly connected), automatically search for the network or manually install the driver, and check whether the corresponding serial port is correctly recognized in the device manager.

b) Open the serial port debugging tool and select the corresponding serial port connection. The default serial port baud rate is 115200. According to the GNSS module instruction manual, send the relevant instructions and check whether the board firmware and serial communication are normal.

### 6.2 Radio Configuration

Connect the TYPE-C cable in the AK977H wiring to the computer, and the terminal radio will automatically enter parameter configuration mode. Open the computer serial port debugging tool, select the corresponding serial port number, baud rate 115200 (Windows 7 and above system computers do not need to download serial port drivers), and you can set the parameters of the terminal radio (specific configuration parameters can be found in the configuration instructions in the next section). Please note that after completing the setup, the TYPE-C cable must be disconnected from the terminal radio in order to exit configuration mode and enter normal working mode.

(1) Data Link Protocol:

(2) Frequency (410Mhz-470Mhz)

(3) Working mode: Base station (TX, transmit mode) Mobile station (RX, receive mode)

(4) Power (0.5W, 1W, 2W)

(5) Save configuration:

※Note: The frequency between the base station and the mobile station must be the same, otherwise communication cannot be carried out.

### 6.3 GNSS module instruction configuration

(1) Base station

After the Radio module is set up, send GNSS module startup instructions on the com1 port of the base station's board (the data link module should be in TX transmission mode):

Fix auto

Log com1 rtm1005b ontime 5

Log com1 rtm1033b ontime 10

Log com1 rtm1074b ontime 1

Log com1 rtm1084b ontime 1

Log com1 rtm1094b ontime 1

Log com1 rtm1114b ontime 1

Log com1 rtm1124b ontime 1

Saveconfig

※ Note: As the com1 port of the GNSS module is connected to the com3 port of the Radio module, the differential data of the RTK module must come from the com1 output!

### 6.3.1 Mobile Station Output

The COM3 card on the mobile station side can output corresponding messages, such as:

Interfacemode com1 auto auto on

Log com3 gpgga ontime 1

Saveconfig

## 7 Common configuration instructions for Radio

No.	Name	Grammar	Describe	Value range	Notes
1	Parameter saving	AT&W	Save current configuration parameters (without loss upon power failure)	/	Return OK after sending
2	Frequency table configuration	ATP0=CH TX RX	Configure the sending and receiving frequencies of the channel	-CH: Channel number (00-07) -TX/RX: Frequency value (with 1-5 decimal places, such as 451.125)	If you want to configure multi-channel, follow the following configuration Multi channel example: ATP0=00 451.125 451.125 ATP0=01 452.125 452.125 ... ATP0=07 458.125 458.125 (channel number and frequency separated by a single space)
3	Query frequency table	ATP0?	Query the configured channel frequency information	/	Return format: Channel Tx(MHz) Rx(MHz) DIR 00 451.12500 451.12500 TxARx ...OK
4	Query work parameters	AT8V	Query the current operating parameters of the radio station	/	The returned information includes: model, software version, serial number, baud rate, frequency, protocol, etc
5	Serial port baud rate modification	ATS102=value	Modify serial port baud rate	1-115200; 2-57600; 3-38400; 5-19200; 7-9600	Example: ATS102=7 (set to 9600) Note: After modification, switch the tool baud rate and send AT8W to save
6	Air baud rate modification	ATS103=value	Modify wireless link baud rate	0-4800; 2-9600; 4-19200	ATS103=2(Set as 9600)
7	Transmission power modification	ATS108=value	Set the transmission power level	H (high power); L (low power)	ATS108=H
8	Sending channel settings	ATS131=value	Set the sending channel number for the current job	0-63	ATS131=00 (Select Channel 0)
9	Receiving channel settings	ATS132=value	Set the receiving channel number for the current job	0-63	ATS132=00 (select channel 0)
10	Communication protocol selection	ATS186=value	Select communication protocol	1-TRIMTALK; 2-TRIIMMK3; 4-TT450S; 5-TRANSEOT; 9-SOUTH; 13-SATEL	ATS186=13 (choose SATEL protocol)
11	Modulation method modification	ATS127=value	Modify modulation mode (only supported by TRANSEOT protocol)	0-GMSK; 1-4FSK	ATS127=0(Set as GMSK)
12	Compatibility mode selection	ATS226=value	Choose protocol compatible vendors	0-HARXON; 2-SATEL; 3-ADL; 4-SINO; 5-TOPCON; 6-8-TBD (reserve)	ATS226=0(default HARXON)
13	FEC switch	FEC ON / FEC OFF	Turn on or off FEC function (only valid for SATEL protocol)	ON / OFF	Attention: It needs to be used under the SATEL protocol

14	Work Mode	ATS300=value	Set the radio working mode	0-DUPLEX (full duplex); 1-TXONLY (send only); 2-RXONLY (receive only)	ATS300=0 (full duplex mode)
15	Save parameters	AT8W	Permanently save all current parameter configurations	/	Key step: This command must be executed after configuration is complete

**Key configuration requirements:**

1. Interconnection conditions: The two radio stations need to maintain the following parameters:

Communication Protocol (ATS186)

Sending/receiving frequency point (ATP0)

Airborne baud rate (ATS103)

2. Command format: Each AT command must end with a \r\n (enter line break).

Inserting TYPE-C USB into the computer radio will automatically enter parameter configuration mode, unplugging TYPE-C radio will exit configuration mode (i.e. the terminal will enter normal working mode)

## 8 Typical applications

### Application of high-precision positioning for medium to short distances

In high-precision positioning applications for medium to short distances (<3km), the module can be combined with a data transmission module to form a complete high-precision positioning system with only a small amount of external circuits. It is suitable for applications with a large number of mobile stations in a small range, and the module is fully compatible with other automatic flight control systems such as Pixhawk and APM. The schematic diagram is as follows:

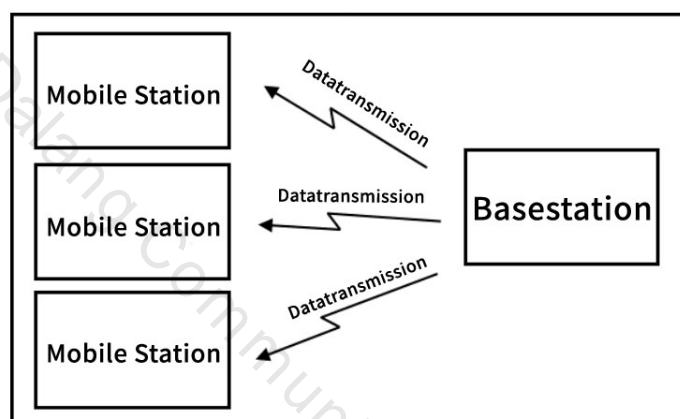

The reference station is stationary and fixed, and differential data is broadcasted to all mobile stations through a data transmission module. The circuit diagrams of the mobile station and the reference station are as follows:

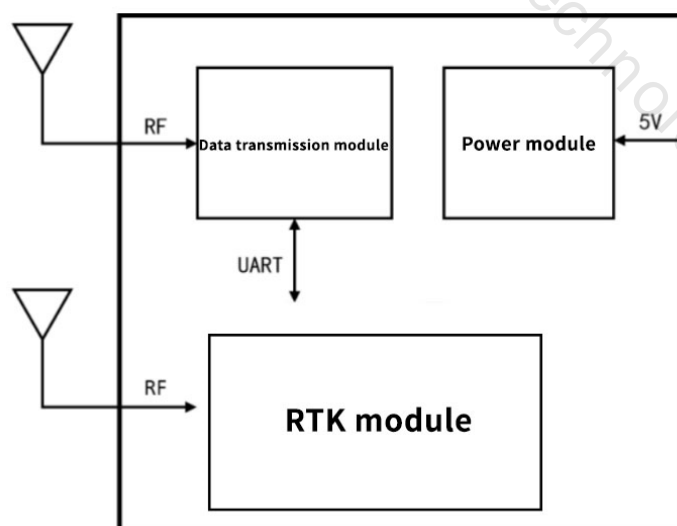

3) If the antenna coordinates have been accurately determined through other surveying methods, please use the # set position command to input the antenna coordinates into the reference station module in latitude, longitude, and altitude format;

- 4) If the antenna coordinates are unknown, please wait patiently for about 5 minutes. The module will calculate the antenna position as accurately as possible. After the calculation is completed, the differential data port will begin to output data. At this point, the base station has already recorded the coordinates and broadcasted them wirelessly to ensure that the base station does not lose power, as the coordinates will be recalculated after a power outage and the repeatability of the mobile station measurement points cannot be guaranteed;
- 5) Install the mobile station antenna on the mobile carrier, confirm receipt of differential data, and wait for about 120 seconds to obtain high-precision positioning results.